

NATIONAL COUNCIL OF SCIENCE MUSEUMS
SECTOR-V, BLOCK-GN, BIDHANNAGAR,
KOLKATA : 700 091.

NOTICE INVITING E-TENDER

TENDER No. : I-18012/3/17(114).

On-line digitally signed e-tenders are invited from reputed manufacturers/authorized dealers for supply of Black Colour (RAL 9005) Powder coated Aluminium Extruded Display Sections including Nylon Lock Assembly and suitable PVC caps as per the Council's drawings and specifications. Vendors having proven experience and capability of executing the order at a time may download the Tender Papers from Central Public Procurement Portal (CPPP): <http://eprocure.gov.in/eprocure/app> or from Council's website www.ncsm.gov.in as per the following schedule:-

Published Date	August 02, 2017
Bid Document Download Start Date	August 02, 2017
Bid Document Download End Date	August 22, 2017
Bid Submission Start Date	August 02, 2017
Bid Submission End Date	August 22, 2017 (upto 11:30 a.m.)
Technical Bid opening date	August 23, 2017 (at 11:30 a.m.)
Financial Bid opening date	August 24, 2017 (at 3:00 p.m.)
Earnest Money	Rs.60,000/- (Rupees Sixty thousand only)

The on-line bid along with the Earnest Money Deposit in the form of scanned copy of the Demand Draft/Pay Order should be uploaded by the due date and time as per the above schedule. No tender will be accepted without requisite EMD. The original EMD in the form of Demand Draft/Pay Order shall be submitted by the bidder to this office either before or at the time of tender opening. The on-line bids will be opened on the scheduled date and time prescribed above. Bidders may be present during opening of tenders, if so desire. Off-line tenders shall not be accepted and no request in this regard will be entertained whatsoever. NCSM reserves the right to accept or reject any or all tenders in full or in part without assigning any reason whatsoever.

General Information and Instructions

1. The instruction given herein will be strictly binding on the tenderers and deviation, if any will make the tender or tenders liable to be considered invalid. Tenders incorporating additional conditions by the tenderer are liable for rejection.
2. Bids shall be submitted online only at CPPP website: <https://eprocure.gov.in/eprocure/app> Manual bids shall not be accepted.
3. The instruction given in “Annexure-A” for “Instruction for Online Bid Submission” should be strictly followed during submission of the Bid.
4. Bid documents may be scanned with 100 dpi with black and white option which helps in reducing size of the scanned document.
5. Bid should be submitted along with the Earnest Money of Rs. 60,000/- (Rupees Sixty thousand only) by way of crossed Demand Draft/Pay Order on any nationalized bank of India payable in favour of “NATIONAL COUNCIL OF SCIENCE MUSEUMS, KOLKATA”. Earnest Money deposit in the form of Bank Guarantee bond or any other bond shall not be accepted and shall be rejected straightway. Earnest Money deposits in respect of such offers which are not accepted will be returned to the Bidders within 30 working days from the date on which the final decision is taken about the source from which the items under tender are to be procured or within 2 (two) months from the date of the opening of the tenders, whichever is earlier. Earnest Money deposit in respect of the successful bidders will be retained with the Council until entire execution of the order as per terms of the tender. If the successful bidder fails to execute the order strictly as per the Council’s drawing & specification in full or part within the stipulated delivery period of the purchase order, the Earnest Money deposit retained with the Council shall be forfeited forthwith after cancellation of the concerned order. No interest will be paid on the Earnest Money deposited with the Council.
6. **Validity of Bids:** The Bids should remain valid for 180 days from the date of bid opening.
7. **Rejection of Bids:** Canvassing by the Bidder in any form, unsolicited letter and post-tender correction may invoke summary rejection. Conditional tenders will be rejected. Non-compliance of applicable General Information and Instruction will disqualify the Bid.
8. The tenderers should have Digital Signature Certificate (DSC) for filling up the Bids. The Person signing the tender documents should be authorized for submitting the on line e-tender.
9. The Financial Bid (BOQ) shall be filled in and signed by the authorized signatory online as per Proforma “Annexure-C” available at Central Public Procurement Portal e-tender system website <http://eprocure.gov.in/eprocure/app>. Off line Financial Bid shall not be accepted.
10. Tender must be uploaded in two separate covers marked Cover-1 and Cover-2. The contents of Cover-1 and Cover-2 will be as follows:-

Cover-1

- i) Scanned copy of General Terms & Conditions as detailed in **Annexure-B** duly signed by the authorised signatory with official stamp as a token of acceptance of the Terms & Conditions.
- ii) Copy of the current and valid Trade License and Dealership Certificate, as applicable, duly signed by the authorised signatory with official stamp.
- iii) Scanned Copy of the current and valid GST Registration Certificate indicating GST number duly signed by the authorized signatory with official stamp. (Please note that Provisional GST Registration Certificate is also acceptable for the time being)
- iv) The scanned copy of the Demand Draft/Pay Order for Rs.60,000/- (Rupees sixty thousands only) as Earnest Money Deposit .
- v) The 'Declaration' of the bidder(as detailed in **Annexure-C**)duly signed by the authorized signatory with official stamp.
- vi) Technical(Techno-Commerical) bid as per "**Annexure-D**" format duly filled in and signed by the authorised signatory with official stamp.
- vii) Scanned copies of the Council's 'Drawings & Technical Specification'(as detailed in **Annexure-F**) duly signed by the authorized signatory with official stamp as a token of acceptance for supply of materials in accordance to the same.

Cover-2

The Financial Bid (as per **Annexure-E** format) i.e. Schedule of Price Bid in the form of attached BOQ Proforma shall be duly filled in, digitally signed and uploaded online by the bidder.

The Cover-1, i.e. Technical (Techno-Commercial)Bid shall be opened by the Council at the first instance and evaluated by the competent authority of the Council. At the second stage, the Cover-2 containing Financial Bid of only techno-commercially acceptable offers shall be opened for further evaluation and ranking before awarding the contract.

11. The authorities of National Council of Science Museums, who does not bind themselves to accept the lowest tender, reserves the right to reject or accept any or all tenders wholly or partially without assigning and reason whatsoever.

**NATIONAL COUNCIL OF SCIENCE MUSEUMS
SECTOR-V, BLOCK-GN, BIDHANNAGAR,
KOLKATA – 700 091.**

TENDER No.: I-18012/3/17(114)

Instructions for Online Bid Submission

1. The bidders are required to submit soft copies of their bids electronically on the CPP Portal, using valid Digital Signature Certificates. The instructions given below are meant to assist the bidders in registering on the CPP Portal, prepare their bids in accordance with the requirements and submitting their bids online on the CPP Portal.
2. More information useful for submitting online bids on the CPP Portal may be obtained at <https://eprocure.gov.in/eprocure/app>

REGISTRATION

- 1) Bidders are required to enroll on the e-Procurement module of the Central Public Procurement Portal (URL: <https://eprocure.gov.in/eprocure/app>) by clicking on the link “**Online bidder Enrollment**” on the CPP Portal which is free of charge.
- 2) As part of the enrolment process, the bidders will be required to choose a unique username and assign a password for their accounts.
- 3) Bidders are advised to register their valid email address and mobile numbers as part of the registration process. These would be used for any communication from the CPP Portal.
- 4) Upon enrolment, the bidders will be required to register their valid Digital Signature Certificate (Class II or Class III Certificates with signing key usage) issued by any Certifying Authority recognized by CCA India (e.g. Sify / nCode / eMudhra etc.), with their profile.
- 5) Only one valid DSC should be registered by a bidder. Please note that the bidders are responsible to ensure that they do not lend their DSC’s to others which may lead to misuse.
- 6) Bidder then logs in to the site through the secured log-in by entering their user ID / password and the password of the DSC / e-Token.

SEARCHING FOR TENDER DOCUMENTS

- 1) There are various search options built in the CPP Portal, to facilitate bidders to search active tenders by several parameters. These parameters could include Tender ID, Organization Name, Location, Date, Value, etc. There is also an option of advanced search for tenders, wherein the bidders may combine a number of search parameters such as Organization Name, Form of Contract, Location, Date, Other keywords etc. to search for a tender published on the CPP Portal.
- 2) Once the bidders have selected the tenders they are interested in, they may download the required documents / tender schedules. These tenders can be moved to the respective ‘My Tenders’ folder. This would enable the CPP Portal to intimate the bidders through SMS / e-mail in case there is any corrigendum issued to the tender document.
- 3) The bidder should make a note of the unique Tender ID assigned to each tender, in case they want to obtain any clarification / help from the Helpdesk.

PREPARATION OF BIDS

- 1) Bidder should take into account any corrigendum published on the tender document before submitting their bids.
- 2) Please go through the tender advertisement and the tender document carefully to understand the documents required to be submitted as part of the bid. Please note the number of covers in which the bid documents have to be submitted, the number of documents - including the names and content of each of the document that need to be submitted. Any deviations from these may lead to rejection of the bid.
- 3) Bidder, in advance, should get ready the bid documents to be submitted as indicated in the tender document / schedule and generally, they can be in PDF / XLS / RAR / DWF/JPG formats. Bid documents may be scanned with 100 dpi with black and white option which helps in reducing size of the scanned document.
- 4) To avoid the time and effort required in uploading the same set of standard documents which are required to be submitted as a part of every bid, a provision of uploading such standard documents (e.g. PAN card copy, annual reports, auditor certificates etc.) has been provided to the bidders. Bidders can use "My Space" or "Other Important Documents" area available to them to upload such documents. These documents may be directly submitted from the "My Space" area while submitting a bid, and need not be uploaded again and again. This will lead to a reduction in the time required for bid submission process.

SUBMISSION OF BIDS

- 1) Bidder should log into the site well in advance for bid submission so that they can upload the bid in time i.e. on or before the bid submission time. Bidder will be responsible for any delay due to other issues.
- 2) The bidder has to digitally sign and upload the required bid documents one by one as indicated in the tender document.
- 3) Bidder has to select the payment option as "offline" to pay the tender fee/EMD as applicable and enter detail of the instrument.
- 4) Bidder should the EMD as per the instructions specified in the tender document. The original should be posted/couriered/given in person to the Tender Processing Section, latest by the last date of bid submission. The detail of the DD/any other accepted instrument, physically sent, should tally with the details available in the scanned copy and the data entered during bid submission time. Otherwise the uploaded bid will be rejected.
- 5) A standard Price Schedule format (BOQ) has been provided with the tender document to be filled by all the bidders. Bidders are requested to note that they should necessarily submit their financial bids in the format provided and no other format is acceptable. If the price bid has been given as a standard BOQ format with the tender document, then the same is to be downloaded and to be filled by all the bidders. Bidders are required to download the BOQ file, open it and complete the white colored (unprotected) cells with their respective financial quotes and other details (such as name of the bidder). No other cells should be changed. **In case no rate value is required to be quoted in any particular cell, that cell must be kept blank, figure '0' (zero) shall not be entered in such cell(s).** Once the details have been completed, the bidder should save it and submit it online, without changing the filename. If the BOQ file is found to be modified by the bidder, the bid will be rejected.
- 6) The server time (which is displayed on the bidders' dashboard) will be considered as the standard time for referencing the deadlines for submission of the bids by the bidders, opening of bids etc. The bidders should follow this time during bid submission.

- 7) All the documents being submitted by the bidders would be encrypted using PKI encryption techniques to ensure the secrecy of the data. The data entered cannot be viewed by unauthorized persons until the time of bid opening. The confidentiality of the bids is maintained using the secured Socket Layer 128 bit encryption technology. Data storage encryption of sensitive fields is done. Any bid document that is uploaded to the server is subjected to symmetric encryption using a system generated symmetric key. Further this key is subjected to asymmetric encryption using buyers/bid openers public keys. Overall, the uploaded tender documents become readable only after the tender opening by the authorized bid openers.
- 8) The uploaded tender documents become readable only after the tender opening by the authorized bid openers.
- 9) Upon the successful and timely submission of bids (ie after Clicking “Freeze Bid Submission” in the portal), the portal will give a successful bid submission message & a bid summary will be displayed with the bid no. and the date & time of submission of the bid with all other relevant details.
- 10) The bid summary has to be printed and kept as an acknowledgement of the submission of the bid. This acknowledgement may be used as an entry pass for any bid opening meetings.

ASSISTANCE TO BIDDERS

1. Any enquiries relating to the tender document and the terms and conditions contained therein should be addressed to the Tender Inviting Authority for a tender or the relevant contact person indicated in the tender.
2. Any queries relating to the process of online bid submission or queries relating to CPP Portal in general may be directed to the 24x7 CPP Portal helpdesk. The contact number for the helpdesk is 1800 233 7315.

**NATIONAL COUNCIL OF SCIENCE MUSEUMS
SECTOR-V, BLOCK-GN, BIDHANNAGAR,
KOLKATA: 700 091.**

TENDER No. : I-18012/3/17(114).

GENERAL TERMS & CONDITIONS (GTC) FOR SUBMISSION OF TENDER FOR SUPPLY OF BLACK COLOUR (RAL 9005) POWDER COATED ALUMINIUM EXTRUDED DISPLAY SECTIONS INCLUDING NYLON LOCK ASSEMBLY AND SUITABLE PVC CAP STRICTLY AS PER COUNCIL'S SPECIFICATIONS AND DRAWINGS.

01. Bidders should have necessary infrastructure and facilities so as to take up the job of supply of the tendered items strictly as per enclosed specifications and drawings with required financial capability.
02. Price:
The prices and rates indicated/quoted shall be inclusive of cost of materials, supply and all incidental charges to deliver the Aluminium Extruded Sections at National Council of Science Museums, Sector-V, Block-GN, Bidhannagar, Kolkata: 700 091. The rate of GST to be imposed on the rate shall be clearly mentioned. Prices and rate quoted shall be firm and fixed for the entire period of execution of the order and no escalation of rate on any ground whatsoever shall be applicable.
03. The successful bidders shall submit the following documents within 7(Seven) days from the date of Placement of the order:-
 - i) Duplicate copy of the order duly signed and stamped as a token of acceptance of the order.
04. Time is the essence of this tender. The delivery shall be made strictly as per following:-

Stage-I

10 pcs of samples of each tendered item strictly as per specifications and drawings should be got approved from NCSM authorities by and before expiry of 15 (fifteen) days from the date of placement of the order. For this purpose, the successful bidder shall submit 10 numbers of samples of each item for inspection and approval to National Council of Science Museums, Kolkata within 10(ten) days from the date of placement of order. The successful bidder shall have to take the entire responsibility to obtain necessary approval of the sample within the above schedule strictly failing which the order shall be cancelled without any further reference and the Earnest Money deposit shall be forfeited forthwith.

Stage-II

Supply of the tendered items as per enclosed specifications and drawings, after obtaining samples approval from the authority of the Council as detailed in Stage-I above, shall be made at National Council of Science Museums, Sector-V, Block-GN, Bidhannagar, Kolkata: 700 091 strictly within 60(sixty) days from the date of placement of the order.

For non-compliance of any of the above terms and non-delivery of the tendered items, complete in all respects within the above stipulated delivery period, the Council shall have the right either to cancel the order or impose penalty as detailed in Clause No.05. Decision in this regard taken by the Council shall be final and binding on the successful bidder.

BULK SUPPLY SHALL BE ACCEPTED ONLY AFTER FINAL APPROVAL OF SAMPLES BY THE COMPETENT AUTHORITY OF THE COUNCIL AS DETAILED IN STAGE-I ABOVE.

05 Penalty Clause:-

The time allowed for executing the supply as detailed in Clause No.04 shall be strictly observed by the successful bidder. The supply shall throughout the stipulated period of the order, be proceeded with all the diligence (time being deemed to be the essence of the order) and the successful bidder shall pay to the Council, an amount equal to 1% of the amount of the contract value for every week that the supply may remain incomplete as per delivery schedule as stipulated in Clause No.04 subject to a maximum compensation of 10% of the contract value after which period, action will be taken by the Council as will deem fit.

The Council may extend the time of delivery of the ordered items at their discretion on the application of the successful bidder for such purpose provided that the Council considers the reasons for such extension as good, sufficient and acceptable.

06. Every effort should be made to complete the supply by the successful bidder within the specified time schedule. In case the firm fails to comply with Clause No.04 within the specified time schedule as per the finalized and accepted terms & conditions, the Council shall have the right to either impose penalty clause or cancel the order forthwith and the earnest money deposit retained with the Council shall be automatically forfeited. The decision of the Council in this regard shall be final and binding on the successful bidder.

07. Payment terms:-

No advance payment shall be made by the Council on any circumstances. Payment shall be released within 30(thirty) working days from the date of receipt of Invoice/Bill(supplies covered under Stage-II of clause No.04) duly supported by receipted challan subject to satisfactory inspection report of the ordered materials issued by the competent authority of the Council.

08. Warranty:

Manufacturer's standard warranty should be offered by the bidder. The bidder shall be responsible for all defects of materials including defective workmanship, use of defective materials etc. for the entire warranty period of the manufacturer effective from the date of final acceptance of the ordered materials.

09. The materials to be supplied by the bidder shall conform to the drawings and specifications given by the Council. Sub-standard quality of materials & workmanship will not be accepted. The samples must be got approved well in advance from the competent authority of the Council.

10. The Council shall not be liable for injury of any employee who are deployed by the bidder within/outside the Council premises at the time of execution of the order.

11. All the Aluminum Extruded Sections and Nylon Lock Assembly shall be supplied with suitable polythene cover on individual bar and Nylon Lock Assembly.

12. Colour Scheme:-

Black Colour (Code: RAL 9005) Powder coated(70 to 100 micron) Aluminium Extruded Sections should be free from any waviness/dents/patch marks. The product should also be free from any embossed/etched/watermark/stickers of manufacture's logo or name.

13. Bad workmanship will not be accepted and if carried out is liable to be rejected and should be rectified by the supplier at his own cost & risk as per specifications and directions given by the authorized representative of the Council.
14. The earnest Money deposit of the successful bidder for Rs.60, 000/- (Rupees Sixty thousand only) shall be retained with the Council as Security Deposit until satisfactory execution of the Purchase Order. In case of failure to execute the order in full or part within the stipulated delivery period of the order or failure to adhere any of the terms & conditions of the Purchase Order, the Earnest Money deposit/Security Deposit retained with the Council shall be forfeited forthwith after cancellation of the concerned Purchase Order.
15. If it is noticed that the goods supplied do not conform to the specification/drawing of the order, the Council shall have the right to reject the materials in part or full. The supplier shall be liable to replace the rejected materials within the stipulated time. Till the replacement is done, the rejected materials shall be lying at the risk, cost and responsibility of the supplier. If the supplier do not arrange to replace the rejected materials within the stipulated time, the same may be disposed off at the risk of the supplier and in the manner which the Council will deem fit. The Council shall be entitled to retain the proceeds of the disposal either in part or in full towards expenses incurred on storage, handling and disposal of the materials. The Council shall also be entitled to recover the expenses made by them on account of storage & handling of such rejected goods till the goods are removed from the premises of the Council.
16. In case the bidder refuse to accept the offer after finalization or does not comply with the Clause No.03 within 15(fifteen) days from the date of placement of the order as per the finalized and accepted terms & conditions, earnest money deposit would be automatically forfeited and the order shall be cancelled forthwith.
17. The authorities of the National Council of Science Museums reserves the right to amend, alter or modify the terms & condition mentioned above if necessary from time to time.
18. The authorities of National Council of Science Museums, who does not bind themselves to accept the lowest tender, reserves the right to reject or accept any or all tenders wholly or partially without assigning and reason whatsoever.
19. The quantities specified in the tender may be decreased or increased at the sole discretion of NCSM authorities.
20. All disputes and differences between the successful bidder and the Council of any kind except quality of workmanship and materials whatever arising out of or in connection with the order on carrying out the supply (whether during the progress of the work or after their completion and whether before or after the determination, abandonment or breach of the Terms & conditions of the order) shall be referred to the sole arbitration of a person nominated by the Director General, National Council of Science Museums, whose decision in this regard will be final and binding on both the successful bidder and the Council.

The provisions of the Arbitration and Reconciliation Act 1996 or any statutory modification or re-enactment thereof and of the rules made there under for the time being in force shall apply to arbitration's proceedings under this Clause.

**NATIONAL COUNCIL OF SCIENCE MUSEUMS
SECTOR-V, BLOCK-GN, BIDHANNAGAR
KOLKATA : 700 091.**

TENDER No. I-18012/3/17(114)

DECLARATION

We do hereby accept the “General Terms & Conditions” as provided by the National Council of Science Museums along with the Tender documents for supply of Black (RAL 9005) Colour Powder Coated Aluminium Extruded Display Sections including Nylon Lock Assembly and suitable PVC Cap and also under take to supply the said materials strictly as per the drawings and specifications of National Council of Science Museums as provided along with the tender documents, in the event of placement of any order on us. The Council shall be at liberty to cancel the order in full or in part and also forfeit the earnest money deposit or security deposit in the event of failure of any of the above declaration made by us.

Signature of the Bidder / Constituted Attorney.

**NATIONAL COUNCIL OF SCIENCE MUSEUMS
SECTOR-V, BLOCK-GN, BIDHANNAGAR,
KOLKATA – 700 091.**

TENDER No.: I-18012/3/17(114)

TECHNICAL (Techno-Commercial) BID

Notes: **ALL PARTICULARS / INFORMATIONS SHOULD BE GIVEN IN THE FOLLOWING FORMAT WITH COMPLETE DETAILS.**

01. Name & Address of the Firm/Bidder :
02. Telephone Number :
- Office :
- Service Center at Kolkata, West Bengal :
03. i) Back ground details of the firm :
(State whether original manufacturer/direct dealer of the manufacturer).
- ii) In case of direct dealers, submit copy of valid dealership license issued by the manufacturer. :
04. Past experience in such business for last 3 years giving details of established clients especially Government offices. Submit satisfactory certificate issued by such clients and Government offices. :
05. i) Whether capable to supply the tendered **Black Colour (RAL 9005) Powder coated Aluminium Extruded Display section** strictly as per enclosed technical specification. (Please mention 'YES' or 'NO') :
- ii) If it is mentioned 'NO' above, submit detailed deviation to be made from the enclosed technical specification. :
- (Extra sheet may be attached, if required).
- iii. If it is mentioned 'YES' above submit copies of product brochure (for product categories) as a proof of their statement. :

Contd.....Page/2

- iv) State whether the **Black Colour (RAL 9005) Powder coated Aluminium Extruded Display section** to be offered by the firm either come with or in compliance with all the features as detailed in enclosed Specification.
(State YES or NO) :
- 07. State the Name & Address of the Manufacturer whose product has been offered / quoted by the tenderer.** :
08. Submit the documentary evidence regarding execution of latest contract of similar nature and magnitude of minimum single order value of Rs. 10 Lakh. :
09. Proof of financial status of the company/ audited Balance Sheet for last 3 years indicating total turnover as well. (Submit documentary evidence). :
10. Whether agreed to accept 30 days credit Payment Terms. (Please mention 'YES' or 'NO' .). :
11. Minimum time required to supply the tendered items at NCSM Hqrs. at Kolkata. :
12. Mention *GST Registration Number* and attach current valid GST Registration Certificate. :
13. Whether agreed to supply the tendered items as per enclosed list positively by 60 (sixty) days and failing which ready to absorb heavy penalty, if any order is placed on the bidder after observing due tender procedure. (Please mention 'YES' or 'NO'). :

I/We hereby declare that the above statements are true. I/We also declare that the decision of National Council of Science Museums regarding selection of eligible firms for opening of Financial Bid (Part-II) shall be final and binding on me/us.

Dated

Official Seal

Signature_of the Tenderer/Constituted Attorney

PRICE SCHEDULE (BOQ)

BOQ-114.xls [Compatibility Mode] - Microsoft Excel

Home Insert Page Layout Formulas Data Review View Nitro PDF Professional

A7

Validate Print Help **Item Wise BoQ**

Tender Inviting Authority: NATIONAL COUNCIL OF SCIENCE MUSEUMS

Name of Work: SUPPLY OF ALUMINIUM EXTRUDED DISPLAY SECTION DULY POWDER COATED WITH BLACK COLOUR CODE RAL-9005

Contract No: 118012/17(154)

Bidder Name:

PRICE SCHEDULE (ANNEXURE - E)
[DOMESTIC TENDERS - RATES ARE TO GIVEN IN RUPEES (INR) ONLY]
 (This BOQ template must not be modified/replaced by the bidder and the same should be updated after filling the relevant columns, else the bidder is liable to be rejected for this tender. Bidders are allowed to enter the Bidder Name and INR Values only).
 In case no rate value is required to be quoted in any particular cell, that cell must be kept blank, figure '0' (Zero) shall not be entered in such cell(s).

NUMBER #	TEXT #	TEXT #	NUMBER #	TEXT #	NUMBER #	NUMBER #	NUMBER #	NUMBER #	NUMBER #	TEXT #
Sl. No.	Item Description	Item	Quantity	Units	BASIC RATE To be entered by the Bidder (Per Unit)	GST (in percentage %)	Warranty Period (in Years)	TOTAL AMOUNT	TOTAL AMOUNT With GST	TOTAL AMOUNT In Words
1	Supply of Aluminium Extruded Display Section Black Colour Powder Coated : COLOUR CODE RAL-9005 on FOR Bidhannagar basis as per following sizes :-						20			
1.01	Square Vertical SV 8 as per attached technical specification	FEM 1.1	200.00	Nos				0.00	0.00	INR Zero Only
1.02	Octagonal Vertical OV 8 as per attached technical specification	FEM 1.2	150.00	Nos				0.00	0.00	INR Zero Only
1.03	Octagonal Vertical OV 2.5 as per attached technical specification	FEM 1.3	100.00	Nos				0.00	0.00	INR Zero Only
1.04	Horizontal plain H2 as per attached technical specification	FEM 1.4	150.00	Nos				0.00	0.00	INR Zero Only
1.05	Horizontal plain H4 as per attached technical specification	FEM 1.5	200.00	Nos				0.00	0.00	INR Zero Only
1.06	Horizontal Single web HSW 2 as per attached technical specification	FEM 1.6	100.00	Nos				0.00	0.00	INR Zero Only
1.07	Horizontal Single web HSW 4 as per attached technical specification	FEM 1.7	150.00	Nos				0.00	0.00	INR Zero Only
2	Byton Lock Assembly for the above Aluminium sections as per attached technical specification	FEM 2	1500.00	Nos				0.00	0.00	INR Zero Only
3	PVC Cap for OV Bar	FEM 3	300.00	Nos				0.00	0.00	INR Zero Only
Total in Figures								0.00	0.00	INR Zero Only
Quoted Rate in Words								INR Zero Only		

Ready

3:32 PM 8/2/2017

DRAWING

ANNEXURE -F

(i)

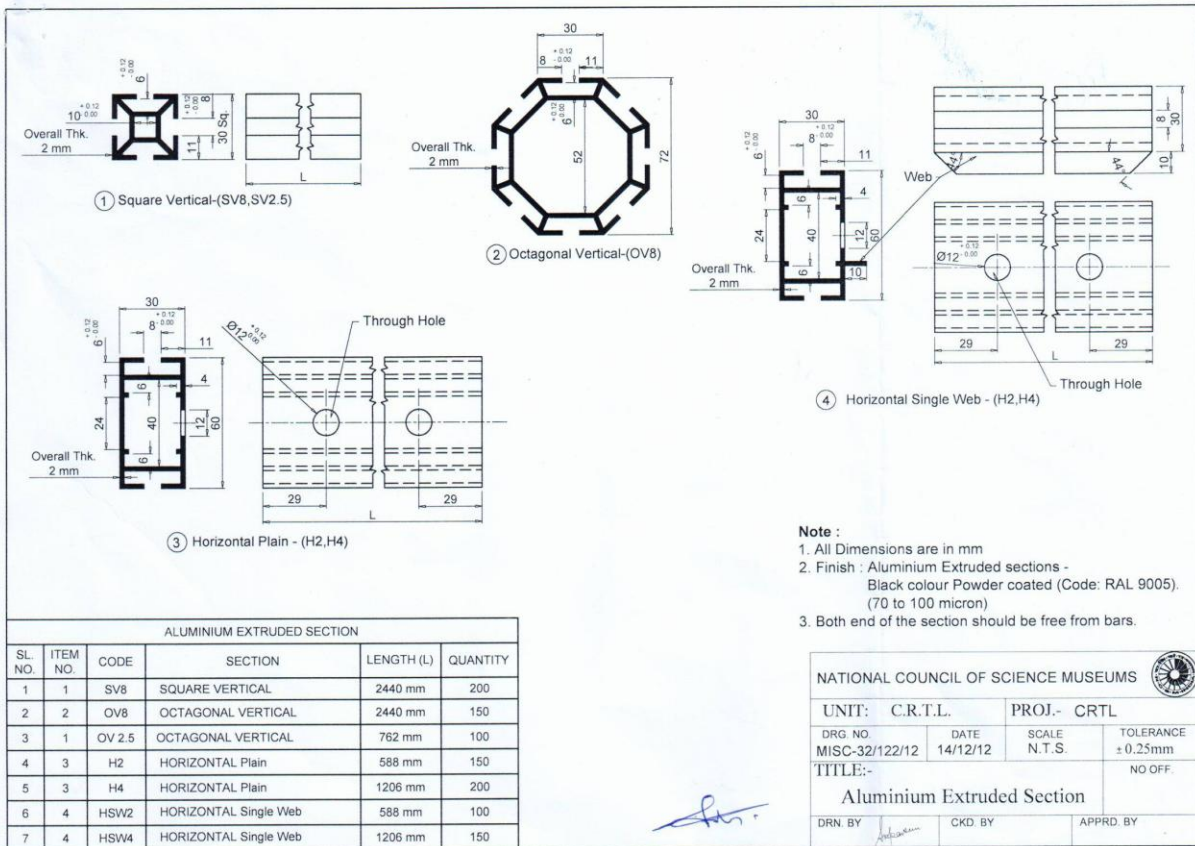

DRAWING

ANNEXURE -F

(ii)

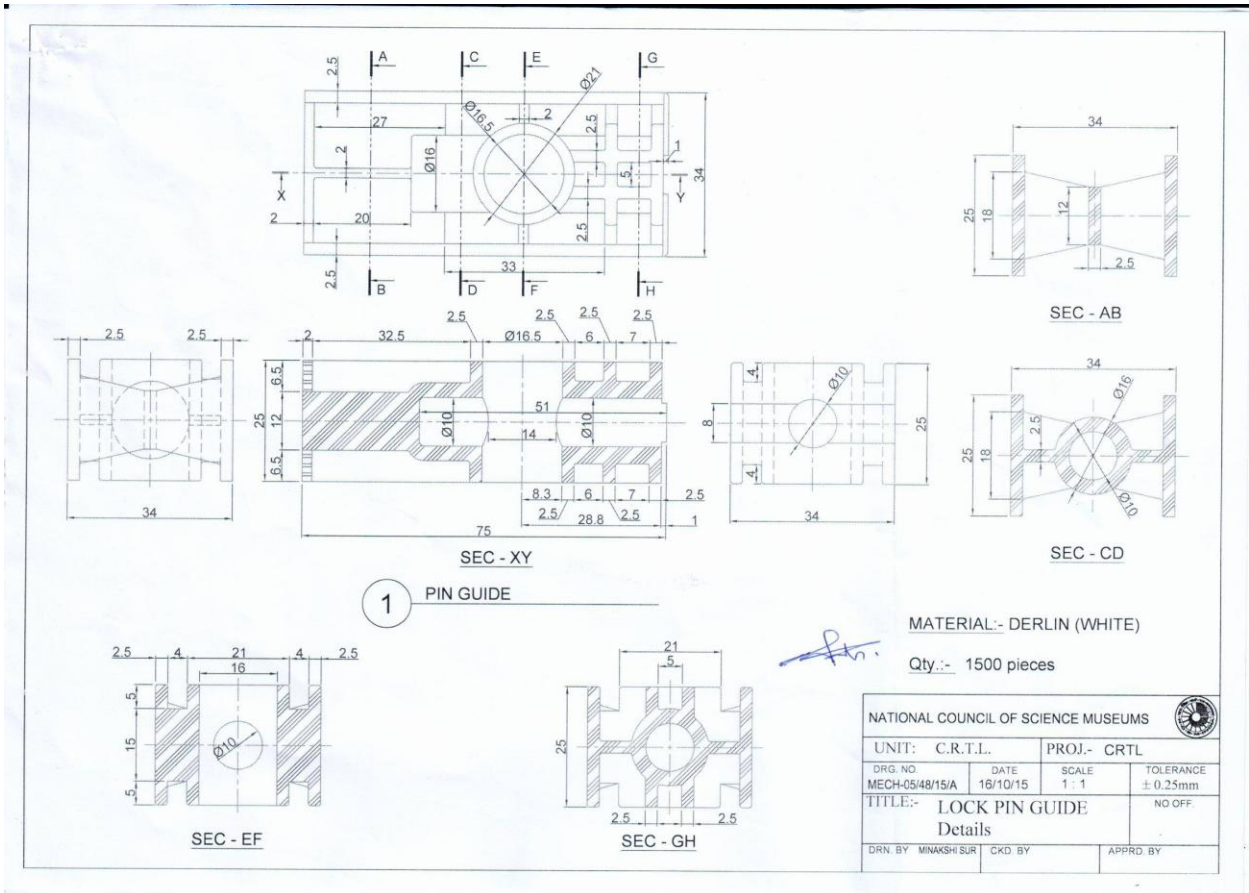

DRAWING

ANNEXURE -F

(iii)

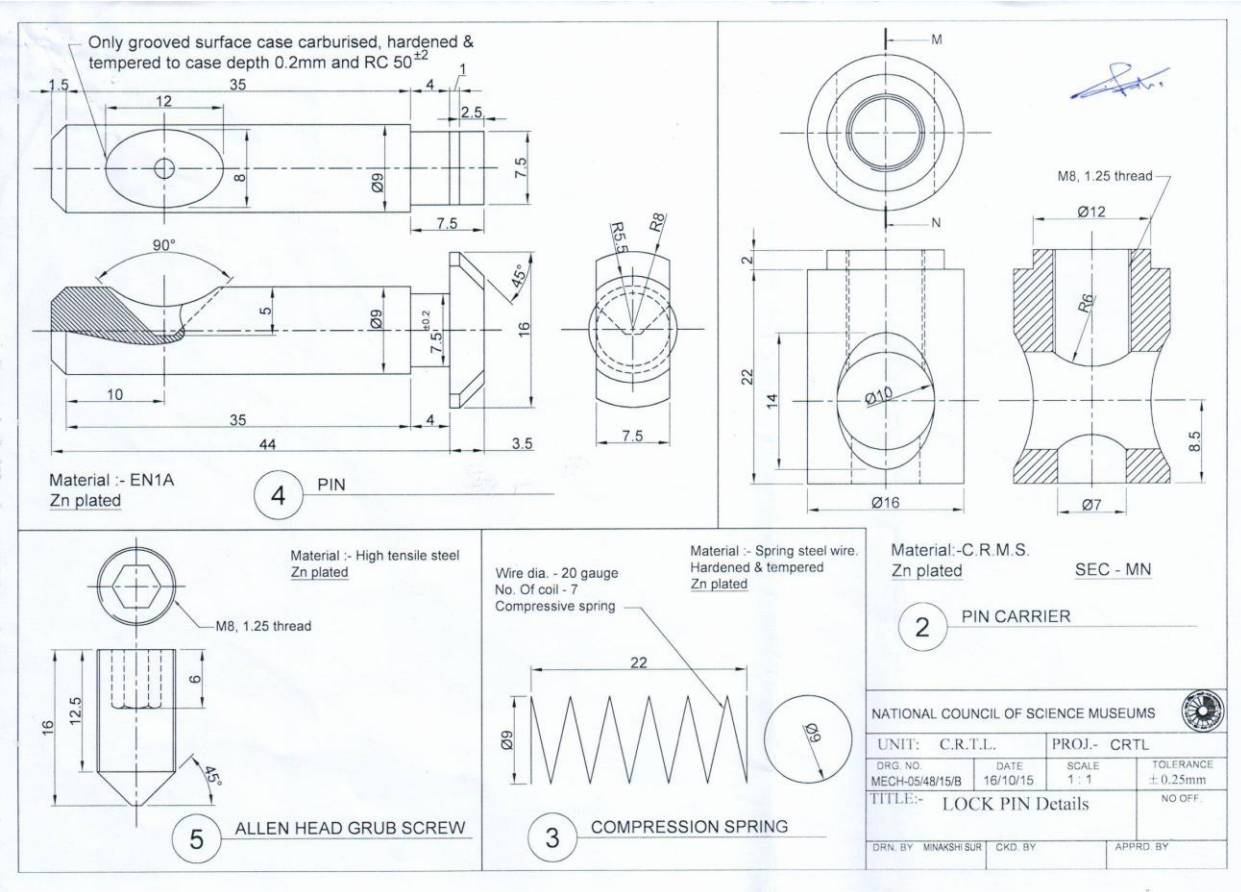

DRAWING

ANNEXURE -F

(iv)

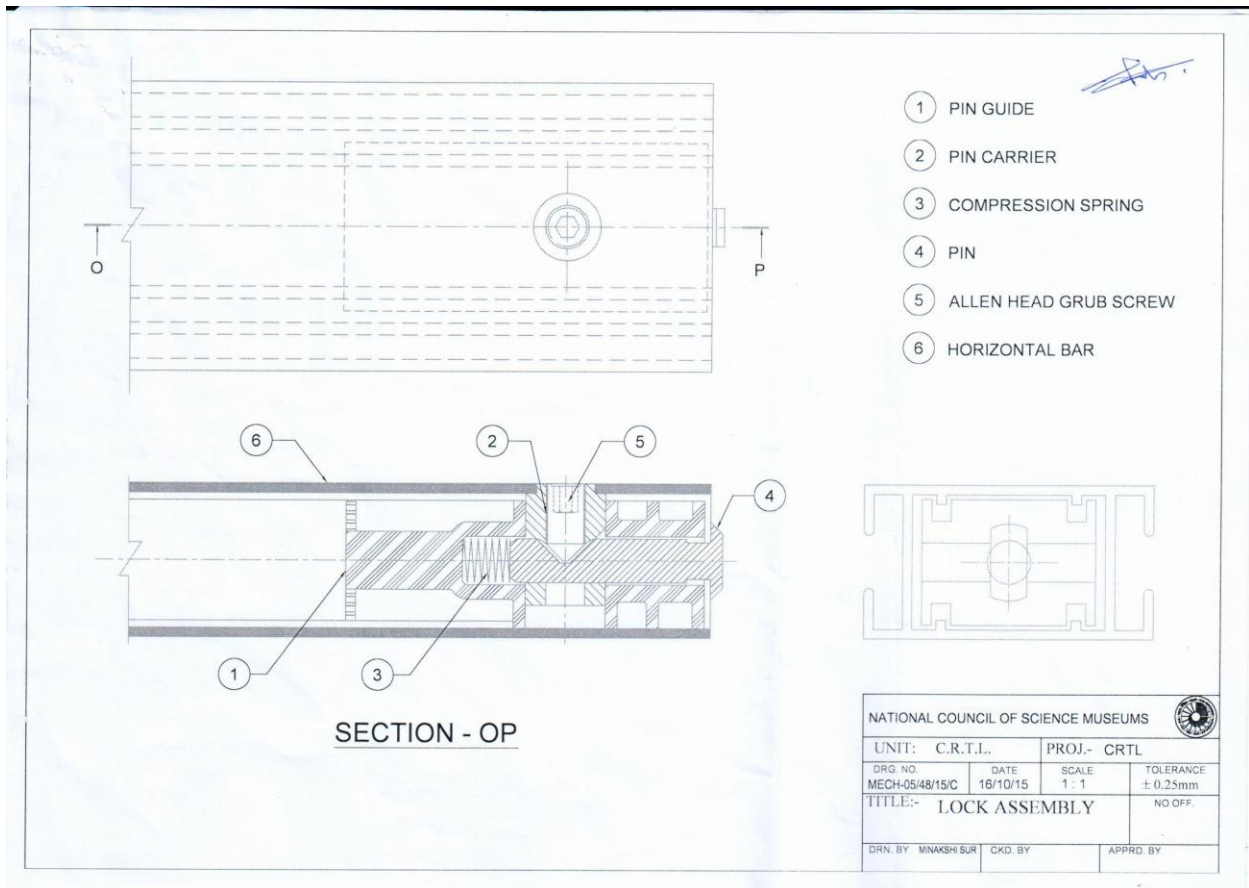

DRAWING

ANNEXURE -F

(v)

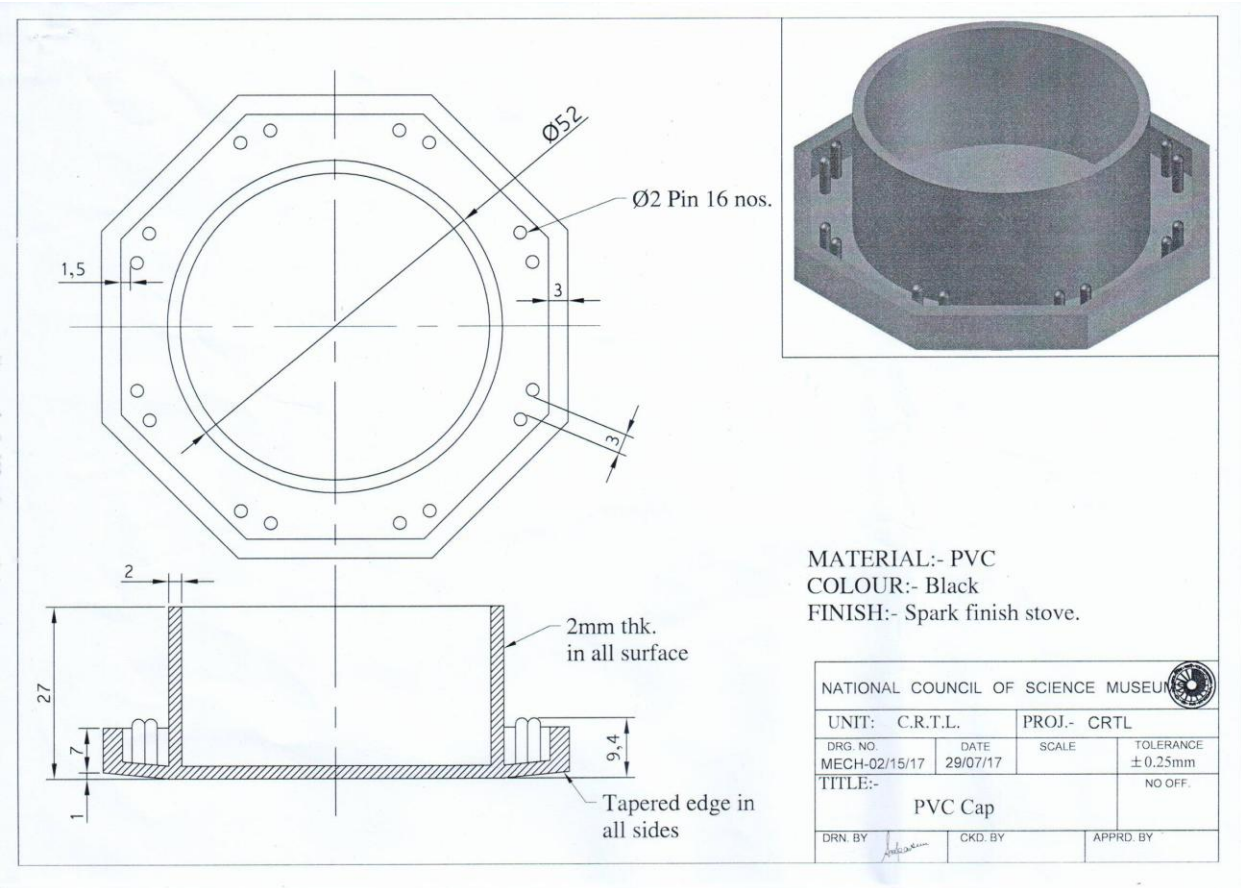

**NATIONAL COUNCIL OF SCIENCE MUSEUMS
SECTOR-V, BLOCK-GN, BIDHANNAGAR
KOLKATA : 700 091.**

TENDER No. I-18012/3/17(114)

TECHNICAL SPECIFICATION

Aluminium Extruded Display Sections- Black Colour Powder Coated

Sl. No	Particulars	Quantity (Nos.)	Specification
1.	Square Vertical SV 8	200	<ul style="list-style-type: none"> • Dimension: Strictly as per drawing. • Finish : Aluminium Extruded Sections-Black Colour (Code: RAL 9005) Powder coated. • Thickness of Anodizing: (70 to 100 micron) • Powder coated surface should be free from any waviness/ dents/ patch marks. • Powder coated surface should be free from any embossed /etched/ watermarks/stickers of manufacturer's logo or name. • All the sections should be supplied with individual transparent reusable protective wrapper.
2.	Octagonal Vertical OV 8	150	
3.	Octagonal Vertical OV 2.5	100	
4.	Horizontal Plain H 2	150	
5.	Horizontal Plain H 4	200	
6.	Horizontal Single web HSW 2	100	
7.	Horizontal Single web HSW 4	150	
8.	Nylon Lock Assembly	1500	
9.	Bar Cap(PVC) - Black	300	