

**NATIONAL COUNCIL OF SCIENCE MUSEUMS
(MINISTRY OF CULTURE, GOVT OF INDIA)
33, BLOCK GN, SECTOR V
BIDHAN NAGAR
KOLKATA – 700091**

e-TENDERDOCUMENT

FOR

**SUPPLY, INSTALLATION, INTEGRATION, TESTING, COMMISSIONING AND THREE
YEARS ONSITE MAINTENANCE OF “DIGITAL & IMMERSIVE EXPERIENCE IN THE
RECEPTION HALL AND OTHER AREAS”.**

AT

NATIONAL MUSEUM
NEW DELHI

INDEX

| Sl.No. | Nomenclature | Page No(s). |
|---------------|--|--------------------|
| 1. | Disclaimer and Disclosures | 3 |
| 2. | Tender schedule | 4-5 |
| 3. | General Information and Instructions | 6-7 |
| 4. | Instructions for Online Bid Submission | 8-10 |
| 5. | Introduction | 11-12 |
| 6. | Eligibility Criteria | 12-13 |
| 7. | Proof of Concept (PoC) | 13 |
| 8. | Scope of Contract | 13-14 |
| 9. | Scope of Work | 15-18 |
| 10. | Earnest Money Deposit | 18-19 |
| 11. | Retention Money/Security Deposit | 19-20 |
| 12. | Joint Ventures/Consortium | 21-22 |
| 13. | Evaluation / Selection Criteria | 22 |
| 14. | Completion Time, Defect Liability Period, Terms of Payment | 22-24 |
| 15. | Other Terms & Conditions | 24-25 |
| 16. | Bill of Quantities | 26-27 |
| 17. | Technical (Techno-Commercial Bid) (Annexure – B) | 28-30 |
| 18. | Financial Bid Format (Annexure ‘C’) | 31-33 |
| 19. | Agency Experience (Private/PPP/JV Projects)(Annexure-D) | 34 |
| 20. | Formation for availability of Technical Team (Annexure-E) | 35 |
| 21. | Format for annual turnover (Annexure –F) | 36 |
| 22. | Declaration (Annexure – G) | 37 |
| 23. | Format For Articles of Agreement (Annexure – H) | 38-40 |
| 24. | Detailed Specifications (Annexure- I) | 41-70 |
| 25. | Cost Break Up (Annexure- J) | 71-74 |
| 26. | Drawings (Annexure – K) | 75-76 |
| 27. | Check List | 77 |

Disclaimer & Disclosures:

NCSM, Kolkata has prepared this document to give background information on the captioned project to the interested bidders/agencies/contractors. While NCSM has taken due care in preparation of the information contained herein and believe it to be accurate, neither NCSM nor NATIONAL MUSEUM nor any of its authorities or agencies nor any of their respective officers, employees, agents or advisors give any warranty or make any representations, express or implied as to the completeness or accuracy of the information contained in this document or any information which may be provided in association with it.

The information is not intended to be exhaustive. Interested agencies/contractors are required to make their own inquiries and respondents will be required to confirm in writing that they have done so and they do not rely only on the information provided by NCSM in submitting the Tender. The information is provided on the basis that it is non-binding on NCSM/NM or any of its authorities or agencies or any of their respective officers, employees, agents or advisors.

NCSM/NM reserves the right not to proceed with the Project or to change the configuration of the Project, to alter the time table reflected in this document or to change the process or procedure to be applied. It also reserves the right to decline to discuss the matter further with any bidder submitting the Tenders.

No contractual obligation on behalf of NCSM, whatsoever, shall arise from this tender unless & until a formal contract is signed and executed by duly authorized officers of NCSM and the bidder in due course after invitation of tenders.

NCSM may modify any / all of the terms of this tender process giving due notification through the NCSM's website (www.ncsm.gov.in).

NCSM will not be liable for any costs incurred by the Bidders in the preparation of the tender & its presentation. The preparation of Bidder's proposal will be made without obligation by NCSM to acquire any of the items included in the Bidder's product, or to select any Bidder's proposal, or to discuss the reasons why a particular Bidder's proposal is accepted or rejected.

All information included by the bidders in their proposal will be treated in strict confidence.

National Council of Science Museums, Kolkata

TENDER

Tender No: I-18012/7/20(126)

Name of the work: Supply, Installation, Integration, Testing, Commissioning and Three Years Onsite Maintenance of “Digital & Immersive Experience in the Reception Hall and Other Areas” at National Museum, New Delhi.

All bids must conform to the guidelines set out in the Tender Document.

On-line Digitally signed e-tenders under LCS (Least Cost Selection) method are invited in Two Bid System from competent Company/Firm/Agency/Consortium, who satisfy the eligibility criteria enumerated in the Tender Document, and having experience of similar nature of work of Supply, Installation, Integration, Testing, Commissioning and Three Years Onsite Maintenance of “Digital Experience in the Reception Hall and Orientation Hall” at National Museum, New Delhi. Interested Agencies may download the tender documents from the Central Public Procurement Portal (CPPP): <http://eprocure.gov.in/eprocure/app> or from the Council’s website www.ncsm.gov.in as per the following schedule:-

SCHEDULE:

| | | | |
|----|--|---|------------|
| 1 | Bid Document Published Date | October 21, 2020 | 05.00 p.m. |
| 2 | Bid Document Download Start Date | October 21, 2020 | 06.00 p.m. |
| 3 | Bid Document Download End Date | November 12, 2020 | 12.00 noon |
| 4 | Bid Clarification Start Date | October 21, 2020 | 04.00 p.m. |
| 5 | Bid Clarification End Date | November 11, 2020 | 04.00 p.m. |
| 6 | Bid Submission Start Date | October 22, 2020 | 06.00 p.m. |
| 7 | Bid Submission End Date & Time | November 12, 2020 | 12.00 noon |
| 8 | Earnest Money Deposit (EMD) | Rs. 14.00 lakh (Rupees Fourteen Lakh only) Original EMD instrument shall be submitted by the bidder at National Council of Science Museums, 33 Block GN, Sector V, Bidhan Nagar, Kolkata - 700091 on or before July 08, 2020 at 12 noon. | 12 noon |
| 9 | Technical (Techno-Commercial) Bid Opening Date | November 13, 2020 | 12.00 noon |
| 10 | Date Place of Technical Presentation | <i>To be notified later, if required</i> | |
| 11 | Financial Bid opening Date | <i>To be notified later</i> | |

1. Tender document can be downloaded from Central Public Procurement Portal (CPPP) website “[http:// eprocure.gov.in](http://eprocure.gov.in)”
2. **Visit of the NM, New Delhi Campus:** Bidders are advised to visit the National Museum at New Delhi premises and ascertain the nature and quantum of work before tendering.
3. Submission of the Bid: This Tender is an e-Tender and bids are to be submitted through CPP Portal (<http://eprocure.gov.in>) only. Bids submitted in physical forms will be summarily rejected.
4. Details of Tender fee, EMD, submission of tender, etc. are indicated in the tender document.
5. The online bid both Technical (Techno-Commercial) Bid and Financial bid duly furnished in Cover –I and Cover-II respectively should be uploaded by the due date and time as per the above schedule. The responsibility to ensure the same lies with the bidders.
6. NCSM reserve the right to amend / withdraw any of the terms and conditions in the Tender Documents or to reject any or all Tenders without giving any notice or assigning any reason. NCSM also reserves the right to accept or reject any or all tenders in full or part without assigning any reason whatsoever. NCSM shall also not be bound to accept merely the lowest tender but the technical suitability, capability and superiority of the concept/ technology interface/system etc. shall be of prime consideration for selection of the appropriate set of concept/ technology interface /system collectively considered as a complete solution.

(Dy. Controller of Stores & Purchase)
National Council of Science Museums
Kolkata

Date: 21.10.2020

The due date for submission of Tender is 12:00 hrs on November 12, 2020.

This document is the property of National Council of Science Museums (NCSM), Kolkata which may not be copied, distributed or recorded on any medium, electronic or otherwise, without NCSM's written permission thereof, except for the purpose of responding to NCSM for the said purpose. The use of the contents of this document, even by the authorized personnel / agencies for any purpose other than the purpose specified herein, is strictly prohibited and shall amount to copyright violation and thus, shall be punishable under the Indian Law.

General Information and Instructions

1. The instructions given herein will be strictly binding on the bidders and deviation, if any will make the tender or tenders liable to be considered invalid. Tenders incorporating additional conditions by the bidder are liable for rejection.
2. Bids shall be submitted online only at CPPP website: <https://eprocure.gov.in/eprocure/app> Manual bids shall not be accepted.
3. The instructions given in “**Instruction for Online Bid Submission**” should be strictly followed during submission of the Bid.
4. Bid documents may be scanned with 100 dpi with black and white option which helps in reducing size of the scanned document.
5. Bid should be submitted along with the **Earnest Money Deposit (EMD) of Rs.14.00 Lakh (Rupees Fourteen Lakh only)** by way of crossed Demand Draft/Pay Order/drawn on any nationalized bank of India payable in favour of “NATIONAL COUNCIL OF SCIENCE MUSEUMS, KOLKATA”. The EMD can also be submitted by ONLINE TRANSFER to the Bank Account of National Council of Science Museums (NCSM) as per details below (Bank charges shall be borne by the Bidder) :

Bank Details of NCSM

| | |
|-----------------|---|
| Name of Bank: | Indian Overseas Bank |
| Branch Address: | GN-34/2, Sector V, Salt Lake, Kolkata – 700091. |
| SB A/c No. | 164201000000491 |
| IFSC Code: | IOBA0001642 |

After fund transfer, the details such as UTR Number, date etc. shall be typed in the letter head of the Bidder and uploaded separately in Cover-I.

Earnest Money deposit in the form of Bank Guarantee bond or any other bond shall not be accepted and shall be rejected straightway. Earnest Money deposits in respect of such offers which are not accepted will be returned to the bidders within 30 working days from the date on which the final decision is taken about the source from which the items under tender are to be procured or within 2 (two) months from the date of the opening of the financial bids, whichever is earlier. No interest will be paid on the Earnest Money deposited with NCSM. Earnest Money deposit in respect of the successful bidders will be retained with NCSM until entire execution of the order as per terms of the tender including defect liability period and two years Comprehensive AMC period. If the successful bidder fails to execute the order strictly as per the Council’s Scope of work, Bill of Quantities, Technical Specifications and Terms & Conditions in full within the stipulated completion time of the order, the Earnest Money Deposit retained with the Council shall be forfeited forthwith after cancellation of the concerned order.

6. **Validity of Bids: The Bids should remain valid for 90 days from the date of opening of financial bid.**

7. **Rejection of Bids:** Canvassing by the Bidder(s) in any form, unsolicited letter and post-tender correction may invoke summarily rejection of their bid(s). Conditional tenders will also be rejected. Non-compliance of applicable General Information and Instructions will disqualify the Bid.
8. The Bidders should have Digital Signature Certificate (DSC) for filling up the Bids. The person signing the tender documents should be authorized for submitting the on line e-tender.
9. The Bidders shall fill up the Prescribed Format for submission of **Technical (Techno-commercial) Bid as per “Annexure-B”** format duly signed by the authorized signatory. The person signing the tender document should be authorised for submitting the online e-tender.
10. The Financial Bid shall be filled in and signed by the authorized signatory online as per format **“Annexure-C” available at Central Public Procurement Portal** e-tender system website <http://eprocure.gov.in/eprocure/app>. **Off line Financial Bid shall not be accepted.**
11. Tender must be uploaded in two separate covers marked **Cover-1** (Technical Bid) and **Cover-2** (Financial Bid/BOQ). The contents of Cover-1 and Cover-2 shall be as follows:-

Cover-1

- i) “Technical (Techno-Commercial) Bid” (as per **Annexure-B** format) duly filled in and digitally signed with official stamp.
- ii) All relevant documents related to “Eligibility Criteria” as per **Clause 2 of Annexure-A** and “Technical (Techno-commercial) Bid” as per **“Annexure-B”**.
- iii) The Technical Brochures of each equipment with technical explanation for every feature of the product offered by the bidders.
- iv) The scanned copy of the Demand Draft for Rs.14.00 lakh (Rupees Fourteen Lakh only) as Earnest Money Deposit. In case of online transfer of money, the UTR No. of the transaction shall be prepared in the letter head of the bidder/consortium and uploaded.
- v) The scanned copy of “Scope of Work, Bill of Quantities, General Terms & Conditions etc. (**Annexure-A**)” duly signed by the Authorized Signatory with official stamp as a token of acceptance of the same by the bidders.

Cover-2

- i) The “Financial Bid (BOQ)” (as per Detailed Scope of Work and Bill of Quantities) i.e. Schedule of Price Bid in the item wise tabular format duly filled in and digitally signed.
- ii) “Cost Break-up” (As per Annexure J) for each quoted components (as per Detailed Scope of Work and Bill of Quantities) duly filled in tabular format as per Annexure-J and digitally signed with official stamp.

The Cover-1, i.e. Technical (Techno-commercial) Bid shall be opened by NCSM at the first instance and evaluated by the competent authority. At the second stage, the Cover-2 containing Financial Bid of only techno-commercially acceptable offers shall be opened for further evaluation and ranking before awarding the contract.

Instructions for Online Bid Submission

1. The bidders are required to submit soft copies of their bids electronically on the CPP Portal, using valid Digital Signature Certificates. The instructions given below are meant to assist the bidders in registering on the CPP Portal, prepare their bids in accordance with the requirements and submitting their bids online on the CPP Portal.
2. More information useful for submitting online bids on the CPP Portal may be obtained at <https://eprocure.gov.in/eprocure/app>

A. REGISTRATION

1. Bidders are required to enrol on the e-Procurement module of the Central Public Procurement Portal (URL: <https://eprocure.gov.in/eprocure/app>) by clicking on the link “**Online Bidders Enrolment**” on the CPP Portal which is free of charge.
2. As part of the enrolment process, the bidders will be required to choose a unique username and assign a password for their accounts.
3. Bidders are advised to register their valid email address and mobile numbers as part of the registration process. These would be used for any communication from the CPP Portal.
4. Upon enrolment, the bidders will be required to register their valid Digital Signature Certificate (Class II or Class III Certificates with signing key usage) issued by any Certifying Authority recognized by CCA India (e.g. Sify / nCode / eMudhra etc.) with their profile.
5. Only one valid DSC should be registered by a bidder. Please note that the bidders are responsible to ensure that they do not lend their DSC’s to others which may lead to misuse.
6. Bidders may then log-in to the site through the secured log-in by entering their user ID / password and the password of the DSC / e-Token.

B. SEARCHING FOR TENDER DOCUMENTS

1. There are various search options built in the CPP Portal to facilitate bidders to search active tenders by several parameters. These parameters could include Tender ID, Organization Name, Location, Date, Value, etc. There is also an option of advanced search for tenders, wherein the bidders may combine a number of search parameters such as Organization Name, Form of Contract, Location, Date, Other keywords etc. to search for a tender published on the CPP Portal.
2. Once the bidders have selected the tenders they are interested in, they may download the required documents / tender schedules. These tenders can be moved to the respective ‘My Tenders’ folder. This would enable the CPP Portal to intimate the bidders through SMS / e-mail in case there is any corrigendum issued to the tender document.
3. The bidders should make a note of the unique Tender ID assigned to each tender, in case they want to obtain any clarification / help from the Helpdesk.

C. PREPARATION OF BIDS

1. Bidders should take into account the original e-NIT/TENDER and any subsequent corrigendum published on the tender document before submitting their bids.

2. Please go through the tender advertisement and the tender document carefully to understand the documents required to be submitted as part of the bid. Please note the number of covers in which the bid documents have to be submitted, the number of documents - including the names and content of each of the document that need to be submitted. Any deviations from these may lead to rejection of the bid.
3. Bidders, in advance, should get ready the bid documents to be submitted as indicated in the tender document / schedule and generally, they can be in PDF / XLS / RAR / DWF/JPG formats. Bid documents may be scanned with 100 dpi with black and white option which helps in reducing size of the scanned document.
4. To avoid the time and effort required in uploading the same set of standard documents which are required to be submitted as a part of every bid, a provision of uploading such standard documents (e.g. PAN card copy, annual reports, auditor certificates etc.) has been provided to the bidders. Bidders can use “My Space” or “Other Important Documents” area available to them to upload such documents. These documents may be directly submitted from the “My Space” area while submitting a bid, and need not be uploaded again and again. This will lead to a reduction in the time required for bid submission process.

D. SUBMISSION OF BIDS

1. Bidders should log-into the site well in advance for bid submission so that they can upload the bid in time i.e. on or before the bid submission time. Bidders will be responsible for any delay due to other issues.
2. The bidders have to digitally sign and upload the required bid documents one by one as indicated in the tender document.
3. Bidders have to select the payment option as “online or offline” to pay the requisite Earnest Money Deposit (EMD) and enter detail of the instrument.
4. **Bidders should submit the EMD as per the instructions specified in the tender document. The original EMD instrument should be posted/couriered/given in person to NCSM, latest by the last date of bid submission. The detail of the DD/any other accepted instrument, physically sent, should tally with the details available in the scanned copy and the data entered during bid submission time. Otherwise the uploaded bid will be rejected.**
5. A standard Price Schedule format (BOQ) has been provided with the tender document to be filled by all the bidders. Bidders are requested to note that they should necessarily submit their financial bids in the format provided and no other format is acceptable. If the price bid has been given as a standard BOQ format with the tender document, then the same is to be downloaded and to be filled by all the bidders. Bidders are required to download the BOQ file (ratequotesheet for Digital Experience in Reception Hall), open it and complete the blue coloured (unprotected) cells with their respective financial quotes and other details (such as name of the bidders). No other cells should be changed. **In case no rate value is required to be quoted in any particular cell , that cell may be kept blank , figure ‘0’ (zero) shall not be entered in such cell(s) .** Once the details have been completed, the bidders should save it

and submit it online, without changing the filename. If the BOQ file is found to be modified by the bidders, the bid will be rejected.

In addition to the above the **Cost Break-up** shall be submitted in tabular format duly digitally signed with official stamp.

6. The server time (which is displayed on the bidders' dashboard) will be considered as the standard time for referencing the deadlines for submission of the bids by the bidders, opening of bids etc. The bidders should follow this time during bid submission.
7. All the documents being submitted by the bidders would be encrypted using PKI encryption techniques to ensure the secrecy of the data. The data entered cannot be viewed by unauthorized persons until the time of bid opening. The confidentiality of the bids is maintained using the secured Socket Layer 128 bit encryption technology. Data storage encryption of sensitive fields is done. Any bid document that is uploaded to the server is subjected to symmetric encryption using a system generated symmetric key. Further this key is subjected to asymmetric encryption using buyers/bid opener's public keys. Overall, the uploaded tender documents become readable only after the tender opening by the authorized bid openers.
8. The uploaded tender documents become readable only after the tender opening by the authorized bid openers.
9. Upon the successful and timely submission of bids (i.e. after Clicking "Freeze Bid Submission" in the portal), the portal will give a successful bid submission message and a bid summary will be displayed with the bid number and the date & time of submission of the bid with all other relevant details.
10. The bid summary has to be printed and kept as an acknowledgement of the submission of the bid. This acknowledgement may be used as an entry pass for any bid opening meetings.

E. ASSISTANCE TO BIDDERS

1. Any enquiries relating to the tender document and the terms and conditions contained therein should be addressed to the Tender Inviting Authority.
2. Any queries relating to the process of online bid submission or queries relating to CPP Portal in general may be directed to the 24x7 CPP Portal helpdesk. The contact number for the helpdesk is 1800 233 7315.

NATIONAL COUNCIL OF SCIENCE MUSEUMS
SECTOR-V, BLOCK-GN, BIDHANNAGAR,
KOLKATA – 700 091.

TENDER No. I-18012/7/20(126)

Name of the work: Supply, Installation, Integration, Testing, Commissioning and Three Years Onsite Maintenance of “Digital & Immersive Experience in the Reception Hall and Other Areas” at National Museum, New Delhi.

1. INTRODUCTION:

National Council of Science Museums, Ministry of Culture, Government of India invites offers/bids from reputed and experienced agencies in the field of creating digital experience using most modern digital gadgets and techniques and have the proficiency in story telling using digital media at museums/Art Galleries/exhibition/public space, especially in the field public/private museums for undertaking the work of as per the tender at National Museum, New Delhi.

- i. Brief Information of National Museum:** National Museum, the prime cultural organization of India, was inaugurated on 15th August 1949 at President House and moved to its permanent location at Janpath on 18th December 1960. NM started with the mission of three C's i.e. 'Collection', 'Conservation' and 'Communication' through its various programmes. It has 29 permanent galleries, on three floors, representing the museum's diverse collection, which represent the rich heritage of India. Time to time museum collaborates with the cultural organizations of India and outside India to hold national and international exhibitions, workshops and seminars. National Museum is visited by over 4 lakhs people every year.
- ii.** The proposed work is under the renovation plan of National Museum. The reception lobby of the Museum is planned to give a complete digital experience to a visitor, wherein the information about the important museum galleries and objects will be given to the visitors through various modern digital gadgets. A brief orientation will also be given to the visitors adjacent to the Reception Lobby before they start the journey of the Museum.
- iii.** NCSM therefore invites Tenders from Company/Firm/Agency/Consortium with adequate experience, sound financial background and proven capabilities of creating digital experience using most modern digital gadgets and techniques and have the proficiency in story telling using digital media at museums/Art Galleries/exhibition/public space
- iv.** Bidders who are interested to participate should meet the eligibility criteria and submit their duly completed Tenders along with all the required documents in support of their eligibility qualification.
- v.** If at any stage, it comes to the notice of NCSM that any successful/qualified bidder had misrepresented the facts/falsefully claimed any qualification while submitting his tender or at any time subsequently, the agency will be disqualified. And in any such instance, NCSM also reserves the right to take any further action against such bidder under law.

2. ELIGIBILITY CRITERIA:

Name of the work: Supply, Installation, Integration, Testing, Commissioning and three years onsite maintenance of “DIGITAL & IMMERSIVE EXPERIENCE IN THE RECEPTION HALL AND OTHER AREAS AT NATIONAL MUSEUM, NEW DELHI”.

- i. Company/Firm/Agency/Consortium shall have the experience of implementing digital experience using most modern digital gadgets and techniques and have the proficiency in story telling using digital media.
- ii. The bidder could be an Individual, Limited Company/Corporation, Proprietary Firm, Partnership etc. Consortium or Joint Venture are allowed to bid for the Works.
- iii. The bidders should have minimum experience of **5 years** since their establishment. For establishing the same, the bidder should submit copies of **work orders** issued on them as well as copies of **work completion certificate** of the same work.
- iv. The Average Annual Turnover of the Bidder (of the lead partner in case of consortium) for last three financial years(2019-20, 2018-19, and 2017-18) should be minimum **INR 7 Crore**.
- v. The Bidder should have the requisite work experience of **completions** similar projects during the last 5 years ending last day of month previous to the date of issuing of tender as per the details given below:

One similar work of value not less than **Rs. 5.50 Crore** of the estimated cost of work.

Or

Two similar works each of value not less than **Rs. 4.25 Crore** of estimated cost of work.

Or

Three similar works each of value not less than **Rs. 2.75 Crore** of estimated cost of work.

Notes:

Here the **similar works*** means the work of “creating digital experience using most modern digital gadgets and techniques and have the proficiency in story telling using digital media in Museums and other public places”.

The details of qualifying works/projects shall be furnished as per the proforma in **Annexure-D** and if required the bidder shall also facilitate inspection of the above qualifying project(s) by NCSM’s officials to ascertain the performance of the system.

The value of executed works shall be brought to current costing level by enhancing the actual value of work at simple rate of 7% per annum, calculated from the date of completion to the last date of submission of bid or extended date of submission of bid.

- vi. NCSM may inspect any of those at its discretion to verify the credentials of the bidder for the qualifying works/ projects indicated above for which the Bidder shall provide references (including Referee names and contact details) in respect of the projects implemented.

For the purposes of determining Conditions of Eligibility and for evaluating the Proposals under this tender, following projects shall be deemed as Eligible Projects - Similar works as mentioned in Notes under point (v) of Eligibility Criteria for Monument / Museum / Parks / Public Places/ / Memorial / Heritage places / Ethnic / Cultural spaces / and other similar places.

The bidder should provide documentary proof for the above in the form of a work order / supply order / contract document / **completion report**/ testimonials **for completion**.

vii. Even though the bidders meet the above qualifying criteria, they are subject to be disqualified if they have:

- Made misleading or false representation in the forms, statements and attachments submitted in proof of the qualification requirements; and/or
- Record for poor performance such as abandoning the works, not properly completing the contract, inordinate delays in completion, litigation history, or financial failures etc.

viii. Proof of Concept (PoC)

- a. The bidders may be advised to present a proof of concept (PoC) document i.e. scheme for creating the digital experience at the Reception Lobby of the National Museum using latest digital gadgets and techniques. The details of the lobby such as AUTOCAD drawings (plan and elevation) shall be shared with the applicants on request. **Submission of PoC document is mandatory. Non submission of PoC document may lead to summarily rejection of bid.**
- b. The equipment used in the concept should be as per the specifications mentioned in the BoQ only and the entire experience should be controlled **centrally** through a **suitable** server, content management software (CMS) and **networked devices**.
- c. The hardware and the software chosen should be of latest model and the **warranty** from OEM should be taken for 3 years and all licenses proposed should be licensed for lifetime.
- d. **The bidder shall also submit any additional gadgets/equipment/software etc required to execute the Digital & Immersive Experience works as per their submitted proposal. However, they should take the cost of all additional requirement in the quoted price of the bidder.**
- e. Further requirement if any regarding the presentation shall be communicated in due course.

Note: The bidder shall approach NCSM for required drawings. **The bidders should be ready for the demonstration of Proof of concept (PoC) on short notice, say 3 days from the communication from NCSM.**

3. SCOPE OF CONTRACT

The successful e-tenderer shall carry out and complete the works in every respect in accordance with this contract and in accordance with the directions of the officials and to the satisfaction of the officials of NCSM/NM. The Officer in charge may from time to time issue further written instructions, detailed directions and explanations in regard to:

- (a) The variation or modification of the design, quality or quantity of works for the addition or omissions or substitution of any work.
- (b) Any discrepancy in the proposal or between the schedule of quantities and/or specifications.
- (c) The removal from the site of any material brought therein by the successful e-tenderer and the substitution of any other materials there from.
- (d) The removal and/or re-execution of any works executed by the successful e-tenderer.

- (e) The dismissal from the works of any persons employed thereupon.
- (f) The opening up for inspection of any work covered up.
- (g) The amending and making good of any defects.
- (h) The successful e-tenderer shall comply with and duly execute any work comprised in such instructions, detailed directions and explanations, provided always that if the Officer's instructions involved variations from the priced Schedule of Quantities, such instructions shall be issued by the Council and the successful e-tenderer shall take appropriate action.
- (i) Even if not specifically mentioned in the schedule of quantities, the successful e-tenderer shall be deemed to have allowed necessary material, labour, tools and plants etc. required for satisfactory completion of the items of work as indicated in drawings and description given in the specifications.
- (j) The successful bidder shall submit the executable files along with the open source of all soft content developed for this project and shall not use these content for any other purpose with the permission of NM/NCSM
- (k) **Copyright:All the software will be copyrighted with the NM Delhi/ NCSM and no copy will be distributed for any means to other vendors or organization or any promotional activity without any permission from NM Delhi/ NCSM.**

All the content shall be free from any copyright violation and the successful bidder shall give an undertaking to NCSM/NM towards this.

(l) Successful E-Tenderer To Provide Everything Necessary

The successful e-tenderer shall provide everything necessary for the proper execution of the works according to the true intent and meaning of the specifications and bill of quantities taken together, whether the same may or may not be particularly described in the drawings or specifications or included in the bill of quantities, provided that the same is to be reasonably inferred there from and if he finds any discrepancy in the drawings or specifications and bill of quantities, he shall immediately refer the same to the Officer In charge who shall decide which shall be followed. Figured dimensions shall be followed in reference to scale.

(m) Rates

The rates quoted by the Successful e-tenderer shall be paid at net rates. He should include in his rates allowance for increase or decrease in the prices due to market fluctuation. He shall not be entitled to any separate amount on account of GST, other taxes, Labour Cess, duties etc. which are in force or will be enforced or enhanced by Government or local bodies during contract period or after e-tendering. Accepted e-tender rates shall not be changed due to changes in wages of labour either.

The rates considered in the respective items are inclusive of comprehensive maintenance of the entire system for a period of twoyears after completion of the defects liability period of 1 year post the actual satisfactory completion of the entire work in all sense. (Total comprehensive maintenance period of 3 years including Defect Liability period of 1 year)

(n) Quantities

The quantities have been given in schedule of quantities. However, if the bidder feels that some additional quantity for any item is required, that may be added in the breakup and cost due to variation should be taken into account in the final quote.

The e-tenderers shall be deemed to have given Balanced Rates for each item, irrespective of the quantities given. Also irrespective of variation in quantities to any extent the e-tenderer shall be paid at accepted contract rates only. **NCSM reserves the right to increase or decrease quantities to any extent.**

4. SCOPE OF WORK

NCSM/NM desires to provide a digital & **immersive** experience using most modern digital gadgets and techniques and with interesting story telling using digital media, to the visitors of National Museum (NM), New Delhi. **The entire space of the reception or entrance lobby and at other places inside the museum as decided by NM/NCSM need to be utilized to create the world class digital & immersive experience for the visitors.** The scope of work, therefore, includes supply, installation, integration, **networking**, testing, commissioning of all the equipment along with the especially developed software (content and CMS) **for this purpose. The scope also includes training of 5 (five) NM personnel for day to day operation of the system.**

Within the quoted rates, the successful bidder will also provide comprehensive maintenance services for the all the installed equipment and software/content by them for the defect liability period of one year without any additional cost.

After the expiry of the defect liability period of one year, the Comprehensive Annual Maintenance Contract for two years will be executed with NM. **This two years Comprehensive AMC is the part of the scope of work within the quoted rates by bidders.**

The project/work is to be completed within **90 Days** from the date of issuance of the work order/LOI.

A. Major Components of the Scope of Work

- a. Design, Supply, Installation, Testing and Commissioning of all Hardware, Software, Content Development for **55 inch or more Transparent OLED Digital Signage Display** including appropriate Media Server/Computer Server/CPU along with all cables and display enclosure for **showcasing** masterpiece Objects of NM the details of which will be provided by National Museum.
- b. Design, Supply, Installation, Testing and Commissioning of all Hardware, Software, Content Development for **5x2 grid thin bezel multi-touch LED Digital Display Wall using 46-48 inch LED digital signage** including appropriate Media Server/Computer Server/CPU along with all cables and display enclosure for interactive display of NM Objects the details of which will be provided by National Museum.
- c. Design, Supply, Installation, Testing and Commissioning of all Hardware, Software, Content Development for Large Indoor P 2.5mm **LED wall with Holographic illusion (Pepper-Ghost Pyramidal Holographic display)** including appropriate Media Server/Computer Server/CPU along with all cables for display of **video content on National Museum and its** Objects for which information will be provided by National Museum.

- d. Design, Supply, Installation, Testing and Commissioning of all Hardware, Software, Content Development for **Orientation Film by way of 3-Wall Projection Mapping Show using DLP Laser Projectors with necessary lenses** including appropriate Media Server/Computer Server/CPU along with all cables for giving brief information about all the galleries of National Museum, the brief write-up on which will be provided by National Museum.
- e. Design, Supply, Installation, Testing and Commissioning of all Hardware, Software, Content Development and Display **system** for **Technology Engagement for each of the 10 galleries by using any two of the listed technologies as per annexure-I(e)** including appropriate Media Server/Computer Server/CPU along with all cables for giving detailed information about the masterpiece/**selected** Objects of the gallery, which will be provided by National Museum.
- f. Design, Supply, Installation, Testing and Commissioning of all Hardware, Software, Content Development for **Central Content Device Management Software System** including appropriate Media Server/Computer Server/CPU along with all cables and networking component for managing all the devices and contents that have been listed in this tender.
- g. The Content should be developed in such a way that it can also be deployed on National Museum Mobile App and National Museum website and can be integrated with Audio/Tour Guide Mobile App of National Museum.**
- h. Quantity and detailed technical specifications of the items shall be as per Annexure-I of this tender document.**
- i. Programming System, Integration & Soft Commissioning
 - i. System Integration and addressing of all equipment for ease of control.
 - ii. Programming of shows of all installations to create various pre-set schemes, saved to a touch controller.
- j. Modifications/ Alterations: After the setup is soft commissioned, the same will be reviewed by the Client. Upon such review, if there be any suggestion in the concept/integration etc. received from the Client, will need to be incorporated (within reason) without any extra cost before the work is finally commissioned and taken over.
- k. Training to National Museum Staff
 - i. Provide training to the client/owner's staff including the day to day operation & maintenance with minor repairs.
 - ii. Hard copy of ready reckoner (Manual) for the daily operation, checking and diagnosis of day to day faults repairable by client staff should be provided
- l. One Year Defect Liability Period and additional Two years of Comprehensive Annual Maintenance
 - i. The bidder will be required to provide comprehensive maintenance services for the subject digital experience system installed by them for the defect liability period of one year without any additional cost.

- ii. Prior to the expiry of the defect liability period of one year, the Comprehensive Annual Maintenance Contract for two years will be executed by the successful bidder with National Museum within the rates offered by them.
- iii. The successful bidder is supposed to maintain minimum spare at the site in order to keep the downtime less than 24 hrs and is required to complete the two years comprehensive AMC successfully.

B. Detailed guidelines of the scope of work:

- i. Two rectangular hall with dimensions as per drawing in **Annexure- J** shall be used for creating the digital experience. The entire work related to creating the desired shows, as listed in the BoQ given in **Annexure-I** includes supply of equipment (such as Transparent LED Display Panels, Large multi-touch video walls, indoor LED walls, Projectors, Pepperghost pyramidal Holographic display, related media servers/ Computer Server, sound systems, content management system, accessories, cables, software and content) and the allied works such as placement and installation of equipment, integrating the entire equipment through LAN as well as creation of content for all equipment as per the storyline given by National Museum.
- ii. **The experience should be designed within the available built up area and there is no scope for any alteration of floor, ceiling, wall etc. of the hall. The site is an institution of national importance where any major alteration in the building is not possible and any installation is required to be done with utmost sensitivity and care, without damaging the interior of the building.**
- iii. Supply and installation of projectors and mapping of projectors on the given area should be done in accordance with the directive of the OEM, for best results. This shall be in the scope of work.
- iv. Supply and installation of high performance Computer Server/Media Servers supporting Displays being used for playback of digital content and static imagery shall be in the scope of work. The vendor shall provide a user friendly Graphical User Interface to control entire system, including audio system, etc. from the same interface.
- v. Supply and installation of Data cabling to carry lossless video signals from amongst the sources viz. Computer Server and playback system to projectors and high speed data path network (if any) among computing and storage elements through fibre optic cables are also in the scope of the work. Any other cable/connector/adaptor/repeater/audio/video cable etc. if any required shall be in the scope of work.
- vi. Proper dressing up of power and data cabling for all systems and devices so as not to cause interference with video signals and data networks shall be ensured by the successful vendor and shall be in the scope of work.
- vii. Multi-channel audio system with adequate number of speakers and subwoofers depending upon the capacity of visitors in the viewing area as per the layout of the area, complete with amplifier, mixer and high quality speakers etc. shall be in the scope of work.
- viii. The agency shall provide site plan document with plan, elevation and mounting details for placement of all the display units, including Transparent LED panels, multi-touch walls, LED wall, Hologram, Projectors, speakers in the visitors' area, Computer server, Content Management System for control of equipment, audio amplifier, mixer, mic and other allied system.

- ix. All metallic structures for mounting of projectors, speakers, Computer server etc shall be coated with anti-corrosive treatment and painted such that they are made inconspicuous. All safety measures shall be considered while designing for safety of people and equipment.
- x. Preparation of projection surface, if required by using teakwood frame and ply (first grade phenol bonded anti termite of century or green make) and painting the surface with multi-coat of screen goo projection paint is within the scope of work.
- xi. Design and fabrication of stands for keeping and fixing the display units by using the material as specified in the BoQ shall be within the scope of work of the successful bidder.
- xii. The detailed specification of all the equipment and content is provided in Annexures I.

5. EARNEST MONEY DEPOSIT (EMD)

- i. Proposal should necessarily be accompanied by an Earnest Money Deposit for an amount of **Rs.14.00 Lakh**(i.e. 2.0% of estimated cost of the work) in the form of Account Payee Demand Draft/Banker's Cheque/NEFT transfer to NCSM's bank account as per bank details provided in the term sheet. EMD instrument must remain valid for a period of 90 days beyond the final proposal/bid validity period.
- ii. Bids not accompanied by Earnest Money Deposit of the requisite amount with proper validity will be summarily rejected.
- iii. Exemption of depositing EMD is allowed only to the MSME/NSIC registered bidders.

**Document required for availing exemption of EMD for MSME's registered with NSIC:
The following procedure is adopted for the bidders of MSME's registered with NSIC:**

The MSMEs who intent to claim benefits under MSME act, shall fulfil the following, otherwise they run the risk of their bid being passed over as "INELIGIBLE" for the benefits applicable to MSME's and their bid will not be considered for evaluation.

- a. MSMEs which are specified by the Ministry of Micro, Small and Medium Enterprises under MSME Act 2006 and Public Procurement Policy, 2012 as **Manufacturing/ Service Enterprises should have registered with NSIC under its Single Point Registration Scheme (SPRS).**
- b. NSIC certificate with monetary limit indicated should be valid on the scheduled date/ extended date of submission of tender. Certificates without monetary limit will not be considered.
- c. The items of Product/ Services mentioned under NSIC certificate should be the same or similar to the tendered items
- d. The monetary limit stipulated in the NSIC certificate of MSME's should be equal or more than the value of work(s)/Supply is/are "In hand (Progress)" awarded under MSME benefits during the financial year plus estimated cost of this tender for availing EMD exemption.
- e. If monetary limit is less than the value of work(s)/ Supply is / are "In hand (Progress)" awarded under MSME benefits during the financial year plus estimated cost of this tender, they should obtain "Competency Certificate" from NSIC for participating in this tender as well as to avail MSME benefits. The competency certificate should be uploaded along with the tender document.

- iv. The EMD amount shall not bear any interest payable by the NCSM to the successful bidder/un-successful bidder.
- v. EMD of successful bidder shall be retained by the NCSM which will get converted into Retention Money/ Security Deposit is submitted by the successful Bidder. Whereas, EMD of the unsuccessful bidders will be returned after expiry of the final proposal/bid validity and latest on or before the 30th day after the award of the contract.
- vi. EMD shall be forfeited and proposal of bidder shall be cancelled in the following cases:
 - a. if any information or document furnished by the bidder turns out to be misleading or untrue in any material respect.
 - b. if the successful bidder fails to execute the Agreement within the stipulated time as per the format of the Article of Agreement as given in this NIT document in Annexure - H.

6. RETENTION MONEY/SECURITY DEPOSIT:

- i. This shall mean and be 10% of the total cost of work awarded or the final gross value of work done & paid against this contract, whichever is greater.
- ii. The Retention Money or Security Deposit will be deducted & retained @10% of the value of work done & paid through every interim bill which will be inclusive of the Earnest Money already deposited by the successful bidder along with the bid/tender.
- iii. The Retention Money or Security Deposit so retained shall not carry any interest thereon.
- iv. 50% of the Retention Money or Security Deposit shall be refundable to the successful bidder after satisfactory completion of the Defects Liability Period post actual successful completion of the work in all respect & handing over as detailed under TERMS OF PAYMENT.
- v. Balance 50% of the Retention Money or Security Deposit shall be refundable after satisfactory completion of the Comprehensive Annual Maintenance Contract with National Museum for a period of 2 years post the Defects Liability Period of 1 year as detailed under TERMS OF PAYMENT.
- vi. In case of cancellation of the contract, this retention money shall be forfeited and amount necessary to make up this amount shall be recovered from any money due to the successful bidder under this or any other contract with NCSM.
- vii. In case, the successful bidder causes any damage to the property of the Client, the NCSM shall have discretionary rights to execute the repair of damages and recover the amount from the successful bidder or to adjust the equivalent amount from the successful bidder's Security Deposit.
- viii. In case of death of successful bidder, Security Deposit shall be returned /refunded to the legal heir of the successful bidder after adjustment of dues, if any post the actual completion

of the work & upon expiry of the specified guarantee/defects liability period as well as satisfactory completion of CAMC period of two years post the Defect Liability Period.

7. JOINT VENTURES/CONSORTIUM

- i. In the event that the successful bidder is a consortium/joint venture formed, lead partner/prime contractor in whose name the bid was issued, shall be fully and solely responsible for the performance of contract and all works designed and executed under the contract.
- ii. Bids submitted by a consortium or joint venture of maximum two firms including lead partner, all partners shall comply with the following requirements:
 - a. The consortium as a whole must be a sound entity technically and the lead partner must be sound entity financially.
 - b. The Consortium as a whole must satisfy the qualification criteria set forth herein. **The turnover of lead partner must satisfy the eligibility criteria of the tender.** The bid shall contain a statement of the members of the consortium and shall provide all information necessary to satisfy Client/Employer that the Consortium fulfils the qualifying criteria.
 - c. The Bids shall contain **original copy of the Memorandum of Understanding (MOU) on Rs.100. Non-Judicial Stamp paper (or as applicable) between the consortium members** clearly identifying the lead partner, scope and responsibility and financial part of each member in the performance of the contract.
 - d. The consortium members will obtain approval of the Client for any change in the shareholding structure and scope of work or any other terms of MOU.
 - e. The lead partner of the consortium shall be nominated as being in-charge to represent the Consortium in all dealings with the Client/Employer and for providing any information or clarification sought from the Consortium.
 - f. The Bid shall be signed by all the consortium firms by their authorized person. The lead partner shall be authorized to incur liabilities and receive instructions for and on behalf of any and all member(s) of the Consortium and all dealings including billing and payments, shall be done exclusively with the leader of the consortium.
 - g. Only firms or joint ventures that have been qualified under this procedure will be eligible to bid for this project.
 - h. All members of the Consortium shall be liable for the execution of the project in accordance with the terms of the MOA and Contract agreement.
 - i. Any individual bidder or member of a consortium cannot be member in another consortium and participate in this tender.
 - j. All correspondence or communications will be done by the Lead partner (or authorized representative of Lead partner) of consortium.
 - k. Net worth as on the last day of the preceding financial year should be positive during the preceding three consecutive financial years.

1. Bidder submitting their bid shall not be under liquidation, court receivership or similar proceeding.

Notes:

1. Techno-Commercial bids of the agencies that fulfil the above pre-qualification criteria shall be opened.
2. The bidder has to upload the compliance letter on its letterhead duly signed by the authorized signature & other supporting documents as asked for in the bid in scanned format. Failing to submit the same or non-compliance/deviation from any bid terms and conditions, eligibility criteria or technical specifications may result in rejection of the bid.

8. PROPOSAL EVALUATION / SELECTION CRITERIA

A two-stage procedure under Least Cost Based (LCS) Evaluation will be adopted in evaluating the proposals:

A. Technical Evaluation:

- i. **Eligibility Criteria Evaluation: The technical bids will be evaluated against minimum eligibility criteria as outlined in this tender document.**
- ii. **Technical Evaluation: The Technical Evaluation Committee shall evaluate the PoC document/Technical Proposal.**
- iii. **The bidders may be called for Technical Presentations if the Technical Evaluation Committee so desires, to discuss the proposal that is submitted by the bidders in the technical bid, which can be at a very short notice of even three days.**

B. Financial Evaluation

Only the bidders/firms who are shortlisted/found eligible in the technical evaluation based on Eligibility Criteria and Technical Proposal Evaluation will be eligible for their Financial Bid Opening & Financial Evaluation. A least cost selection (LCS) will be deployed for financial evaluation of the bids. Overall cost of the work will be considered for computing LCS.

During financial evaluation, the evaluation committee shall go through the rates quoted for each item and adjudge their reasonability and workability. The rates which are found to be unworkable will be treated as unresponsive and the corresponding bid will be liable for rejection.

9. COMPLETION TIME

The project/work is to be completed within **90 days** from the date of issuance of the work order/LOI.

10. DEFECT LIABILITY PERIOD and COMPREHENSIVE ANNUAL MAINTAINENCE CONTRACT

- i. **Defect Liability Period (DLP) shall be of ONE YEAR** from the date of actual satisfactory completion & handing over of the entire job as certified by the authorities of NCSM/NM.
- ii. The Comprehensive Annual Maintenance Contract (CAMC) will be of TWO YEARS and will commence from the date of satisfactory completion of the Defect Liability Period.
- iii. During the Defect Liability Period and the Comprehensive Annual Maintenance Contract Period (CAMCP), the successful bidder within their quoted rates shall service & maintain the entire façade lighting system installation with all its control units & other accessories, rectify any or all the observed defects or any or all the defects as pointed out to them within a reasonable time, as decided by the competent authority of NCSM/NM.
- iv. During the DLP as well as the CAMCP, minimum 1 visit per quarter will be given by the Service Engineer/Technician of the successful bidder for a thorough inspection, checking, repairs & maintenance of the entire façade lighting system for which all tools, tackles and material including spares as well as the required skilled/specialised manpower shall be arranged by the bidder at their expenses & risk.
- v. Apart from the routine quarterly visits as above, whenever the successful bidder is called for providing any kind of repairs/maintenance, they shall render all such services within a reasonable time, any number of times within the quoted rates and at no extra cost or expenses whether during the DLP or the CAMCP.
- vi. A register of such visits during DLP & CAMCP as well as a log-book of services rendered/ major works done shall be maintained wherein counter signatures of the authorised NCSM/NM representative shall be obtained from time to time.
- vii. A penalty in the form of deduction as deemed fit by NCSM/NM authority shall be applied and be deductible from the Retention Money / Security Deposit of the bidder for any lapse in providing services, rectifying defects or in case of an inordinate delay in attending the faults/defects or responding to the service/breakdown calls.
- viii. If the successful bidder fails to rectify the defects within a reasonable time, such defects will be rectified by NCSM/NM by engaging departmental staff or outside Agencies at their discretion, and the cost thereof, as decided by NCSM will be deducted from the Retention Money / Security Deposit of the successful bidder retained by NCSM.
- ix. The bidder may separately prepare & upload a detailed scope of CAMC with other terms & conditions on their letter head which will be mutually modifiable with the successful bidder during the execution of the work and the DLP.

11. TERMS OF PAYMENT

Total Contract Payment shall be on progressive basis as per the breakup in the following table:

| SL No | On Achieving of Milestone | Payment admissible |
|-------|---------------------------|--------------------|
|-------|---------------------------|--------------------|

| | | |
|---|--|---|
| 1 | On supply of equipment | 50% of the value of the equipment based on the challan/proof of value submitted |
| 2 | On completion of total work as per BOQ | Balance amount of the tender |
| 3 | After completion of 1 year Defect Liability Period | Refund of 50% of Security Deposit |
| 4 | After completion of 2 years of AMC | Refund of balance 50% of Security Deposit |

In case if the work is carried out in phases, total payment admissible will be computed on pro-rata basis based on completed percent of work vis-à-vis total work under consideration.

All payments, as above, shall become payable within fifteen days of submission of the respective invoices. The payment shall be transferred to the bank account of successful bidder through electronic transfer only, for which the bank details of the bidder has to be provided with each invoice.

Statutory deductions/recoveries viz. TDS, TDS GST, Labour Cess, etc. shall be made as per the relevant provisions from the payment due to the bidder from time to time.

12. OTHER TERMS AND CONDITIONS

- i. The successful Bidder shall submit within 3 (three) days from the date of placement of the work order the duplicate copy of the work order duly signed with official stamp on all the pages as a token of their acceptance of the work order/LoI.
- ii. In case the successful bidder refuses to accept the offer after finalisation or does not comply with sending of acceptance of the order within 03 (three) days from the date of placement of the order as per the finalised and accepted terms & conditions, earnest money deposit would be automatically forfeited and the order shall be cancelled forthwith.
- iii. **Penalty Clause :**
In case of non-completion of the entire work within the stipulated time, and the delay is not attributable to site requirements, **Liquidated Damage (L.D.) @1% per week of the total cost of work awarded subject to a maximum of 10% of the gross value of work done or cost of work awarded, whichever is greater,** shall be recovered from the bill of the successful bidder.
- iv. The authorities of NCSM do not bind themselves to accept the lowest tender and reserves the right to accept or reject any or all tenders wholly or partially without assigning any reason whatsoever.
- v. The quoted rate shall remain unchanged during the entire contract period.
- vi. The successful bidder shall be liable for depositing all taxes, levies, cess, etc. on account of service rendered by it to concerned tax collection authorities from the time to time as per extant rules and regulations on the matter.

- vii. The successful bidder shall maintain all statutory registers under the applicable laws. The bidder shall produce the same, on demand, to the concerned authority of this Office or any other authority under Law.
- viii. The Tax Deduction at Source (TDS) shall be affected, as and when applicable, as per the provisions of Income Tax Act, as amended from time to time and a certificate to this effect shall be provided to the bidder/contractor/supplier by this Office.
- ix. In case, the successful bidder fails to comply with any statutory/ taxation liability under appropriate law and as a result thereof this Office is put to any loss/ obligation, monetary or otherwise, this Office (National Council of Science Museums, Kolkata) will be entitled to get itself reimbursed out of the outstanding bills or the Security Deposit of the Agency, to the extent of the loss or obligation in monetary terms.
- x. **Before submitting the offer, bidders may visit the National Museum, New Delhi at their own cost and risk, to get an idea of actual site condition etc. which may help in designing an impressive digital experience, nature & quantum of work.**
- xi. Bidders should provide the details of their local office, service centres in Delhi/NCR for after sales service and maintenance of the entire system.
- xii. The successful bidder shall be required to depute a team of qualified and experienced personnel to co-ordinate, execute and supervise all the activities from commencement till completion and handing over the system. This team of personnel will also be required to monitor the progress and review in consultation with NCSM & NM officials on a regular basis.
- xiii. Bidders should provide escalation matrix of their company for this project. Names of all the persons, contact details along with their designation should be submitted.
- xiv. Bidder should submit the details of the major projects which they have done in the last Five Years.
- xv. Notwithstanding anything contained herein above, in case of any dispute, claim and/or legal action arising out of this contract, the same shall be subject to the jurisdiction of courts at Kolkata only.
- xvi. **Arbitration Clause:** All disputes and differences between the successful tenderer and the Council of any kind, except quality of workmanship and materials, whatever arising out of or in connection with the order on the carrying out of the work (whether during the progress of the work or after their completion and whether before or after the determination, abandonment or breach of the terms and conditions of the order) shall be referred to the sole arbitration of a person nominated by the Director General, National Council of Science Museums, whose decision in this regard will be final and binding on both the successful Tenderer and the Council.

The provisions of the Arbitration and Reconciliation Act 1996 or any statutory modification of the rules made there under for the time being in force shall apply to arbitration's proceedings under this Clause.

13. BILL OF QUANTITY

The detailed list of probable equipment, associated accessories, control system, distribution boards and cables is as follows:

| S.No. | Description | Specification | Qty |
|----------|---|-----------------------|--------|
| A | Design, Supply, Installation, Testing and Commissioning of all Hardware, Software, Content Development and Display Cases for <u>55 inch Transparent OLED Digital Signage Display</u> including appropriate Media Server/Computer Server/CPU along with all cables and display enclosure for showcasing masterpiece Objects of NM which will be provided by National Museum | | |
| 1 | 55 inch Transparent OLED Digital Signage Display, Computer System and graphic card, Cables, Content Development, Display enclosures | As in Annexure –I-(a) | 6 Set |
| B | Design, Supply, Installation, Testing and Commissioning of all Hardware, Software, Content Development and Display Cases for 5x2 grid thin bezel <u>Multi-touch LED Digital Display Wall</u> using 46-48 inch LED digital signage including appropriate Media Server/Computer Server/CPU along with all cables and display cases for display of masterpiece Objects which will be provided by National Museum | | |
| 1. | 5x2 grid thin bezel multi-touch LED Digital Display Wall using 40-42 inch LED digital signage, Computer System and graphic card, Content Development, Display enclosures, Cables etc | As in Annexure –I-(b) | 2 sets |
| C | Design, Supply, Installation, Testing and Commissioning of all Hardware, Software, Content Development for Large Indoor P 2.5mm LED wall with Holographic illusion (Pepper-Ghost Pyramidal Holographic display) including appropriate Media Server/Computer Server/CPU along with all cables for display of video content on National Museum and its Objects for which information will be provided by National Museum. | | |
| 1. | 11' x12' Indoor P 2.5mm LED wall, Computer System and graphic card, Content Development, Display enclosures, Cables etc along with Hologram | As in Annexure –I-(c) | 1 set |
| D | Design, Supply, Installation, Testing and Commissioning of all Hardware, Software, Content Development and Display Cases for <u>Orientation Film by way of 3-Wall Projection Mapping Show using DLP Laser Projectors with necessary lenses</u> including appropriate Media Server/Computer Server/CPU along with all cables and display cases for display of masterpiece Objects which will be provided by National Museum | | |
| | Laser projectors, media servers, Projection mapping software, HDMI Extender receiver/transmitter, Network Switch, Show control system, tablet, Wi-Fi router, Sound System Processor & Speakers, Projector clamps, Cables, Server Rack, Projection Screen, DMX | As in Annexure –I-(d) | |

| | | | |
|---|---|------------------------|-------------------------|
| | artnet lights control, Integration and content | | |
| E | Design, Supply, Installation, Testing and Commissioning of all Hardware, Software, Content Development and Display Cases for <u>Technology Engagement for each of the 10 galleries</u> by using any two of the listed technologies including appropriate Media Server/Computer Server/CPU along with all cables and display cases for giving detailed information about the masterpiece Objects of the gallery, which will be provided by National Museum. (Any two of the technologies mentioned from SI No. 1 to 12 or any other similar latest technology) | | |
| | AR Wall. App with image recognition, Pillar mounted, fixed station type multiple Virtual Reality/ Mixed Reality content, Multi-touch Kiosk Station, Interactive Touch projection Wall, Interactive Kiosk with 3D scanned object content, Linear Seamless Visual Seeker with touch interactive screen, AI based Interaction with digital presence of famous personality, Pepper-Ghost Holographic Display, Virtual Presenter, RFID tagged interactive content, Projection based digital flip book, Eyeball tracking based digital interaction, Computer System and graphic card for each, Content Development, Display Cases, Cables | As in Annexure – I-(e) | |
| G | Design, Supply, Installation, Testing and Commissioning of all Hardware, Software, Content Development and Display Cases for <u>Central Content Device Management Software System</u> including appropriate Media Server/Computer Server/CPU along with all cables and display cases for managing all the devices and contents that have been listed in this tender | | |
| | Content Management Software, Computer System, Mobile Phones and head sets, Operating System Support, Integration, Installation, Cables | As in Annexure –I-(f) | 1 set for all equipment |

- **The Content should be developed in such a way that it can also be deployed on National Museum Mobile App and National Museum website and can be integrated with Audio/Tour Guide Mobile App of National Museum.**
- **Since the L1 will be decided based on the overall lowest quoted rate the cost for all items mentioned in the BoQ should be compulsorily quoted, otherwise the bid would be summarily rejected.**
- Cost should Include GST of as applicable for items quoted.
- Cost should Include Comprehensive Defect Liability Period of ONE YEAR after the completion of work
- Cost should include Comprehensive Annual Maintenance Contract of TWO YEARS after the completion of Defect Liability Period

TENDER NO. I-18012/7/20(126)

Name of the Work: Supply, Installation, Integration, Testing, Commissioning and Three Years Onsite Maintenance of “Digital & Immersive Experience in the Reception Hall and Other Areas” at National Museum, New Delhi.

TECHNICAL (TECHNO-COMMERCIAL) BID

| Sl. No. | Details | Details | Page Nos. |
|----------------------------|--|-------------------------------|-----------|
| | | (to be filled by the bidders) | |
| General Information | | | |
| 1. | Name and Full Address of the bidder with Tel. No, E-mail & Fax Number (s) and Contact person | | |
| 2. | Name and Address of the lead partner of the consortium to whom the order will be placed. (Applicable only for the Consortium) | | |
| 3. | Status of the bidder: - Company / Partnership Firm/ Proprietorship firm/Consortium – Please specify | | |
| 4. | In case of Company – please enclose Memorandum and Articles of Association along with certificates of incorporation, if company is a public limited then the certificate for commencement of business also to be enclosed. | Submitted/ Not Submitted | |
| 5. | In case of Partnership Firm – please enclose Certificate of Registration under the Partnership Act, 1932, along with valid partnership deed. | Submitted/ Not Submitted | |
| 6. | In case of Proprietorship or Individual – please enclose a declaration on the letter head | Submitted/ Not Submitted | |
| 7. | In case of Consortium – please enclose a Memorandum of Understanding (MOU) on Rs.100. Non-Judicial Stamp paper | | |
| 8. | Compliance of statutory laws i) Copy of PAN card ii) Copy of Registration Certificate under GST | Submitted/ Not Submitted | |
| 9. | i) Copy of ESI registration certificate, if applicable ii) Copy of EPF registration certificate, if applicable In case of non-applicability of EPF and / or ESI, the applicant shall submit a declaration to this effect. In case self-declaration is found to be false at any stage then contract will be terminated and the firm will be debarred from future tenders for three years. | Submitted/ Not Submitted | |
| 10. | State the Name of the Banker including IFSC Code and Account | | |

| | | | |
|---------------------------------------|--|--------------------------------|--|
| | Number of the Bidder to follow digital mode of payment. | | |
| Technical Eligibility Criteria | | | |
| 11. | Details of Earnest Money Deposit (EMD) Rs. 14.00 lakh (Rs. Fourteen Lakh), through Demand Draft/Pay Order/NEFT/RTGS, in favour of National Council of Science Museums. | Submitted/ Not Submitted | |
| 12. | Company/Firm/Agency/Consortium shall have the experience of implementing digital experience using most modern digital gadgets and techniques and have the proficiency in story telling using digital media. | Submitted/ Not Submitted | |
| 13. | The bidders should have minimum experience of 5 years since their establishment. For establishing the same, the bidder should submit copies of work orders issued on them as well as copies of work completion certificate of the same work.(Annexure – D) | Submitted/ Not Submitted | |
| 14. | The Average Annual Turnover of the Bidder (of the lead partner in case of consortium) for last three financial years (2019-20, 2018-19, and 2017-18) should be minimum INR 7 Crore . (Annexure – F) | Submitted/ Not Submitted | |
| 15. | The bidder should have executed one single similar work of at least Rs. 5.50 Crore or two similar works of Rs. 4.25 Crore each or three similar works of 2.75 Crore each in last three years. (Annexure-D) | Submitted/ Not Submitted | |
| 16. | Bidders should submit the presentation on their past experience of the similar work, and the Proof of Concept (PoC) at NCSM in an appropriate media through hand delivery/post/courier/email before the final date of submission of the tender. | Submitted/ Not Submitted | |
| 17. | Documentary evidences like Work Order, Completion Certificate, Income Tax Return, Audited Report, and Financial Statement, Valid MSME/NSIC Registration Certificate etc. to support. Sl no-12 to 15above. | Submitted/ Not Submitted | |
| 18. | Whether the cost for all the items mentioned in the BoQ as per item no 13 of Annexure-A as detailed in Annexure I, has been quoted in the financial bid | Yes/No | |
| 19. | Whether “Cost Break-up” for each quoted components (as per Detailed Scope of Work, Bill of Quantities and Annexure-I) duly filled in tabular format as per Annexure-J and digitally signed with official stamp. | Yes/No | |

I/We hereby declare that the above statements are true. I/We also declare that the decision of National Council of Science Museums regarding selection of eligible firms for opening of Financial Bid (Part-II) shall be final and binding on me/us.

Date:

Official Seal

/

Constituted Attorney

Signature of the Tenderer

Note: -

1) The Technical bids received shall be evaluated on the basis of eligibility criteria.

- 2) Non submission of any of the documents listed in 'General Information and Technical Eligibility Criteria', mentioned above, shall lead to summarily rejection of the offer. No further correspondence in this regard will be made. However, clarification may be asked on the 'General Information' mentioned above.
- 3) English translation of all such documents which are written in foreign language is required to be submitted.

TENDER NO. I-18012/7/20(126)

Name of the Work: Supply, Installation, Integration, Testing, Commissioning and Three Years Onsite Maintenance of “Digital & Immersive Experience in the Reception Hall and Other Areas” at National Museum, New Delhi.

FINANCIAL BID FORMAT

Rate NOT to be quoted here. To be quoted in excel sheet at CPP Portal

| Tender Inviting Authority: Director General, National Council of Science Museums, Kolkata. | | | | | |
|--|--|-----------------|--------------|--------------------------------|--|
| Name of Work: Supply, Installation, Integration, Testing, Commissioning and Three Years Onsite Maintenance of “Digital & Immersive Experience in the Reception Hall and Other Areas” at National Museum, New Delhi. | | | | | |
| Contract No: I-18012/7/20(126) | | | | | |
| Name of the Bidder/ Bidding Firm / Company : | | | | | |
| <u>PRICE SCHEDULE</u> | | | | | |
| (This is a just a format of the actual BOQ template and must not be filled here. The actual BoQ is available in Excel Sheet on CPP portal. Only the relevant columns of the BoQ available at CPP portal should be filled. No other format is acceptable.) | | | | | |
| Sl. No. | Item Description | Quantity | Units | Estimated Rate in Rs. P | TOTAL AMOUNT including Taxes in Rs. P |
| 1 | 2 | 3 | 4 | 5 | 6 |
| 1 | Digital Experience of Reception area of National Museum Design & SITC: | | | | |
| 1.01 | Design, Supply, Installation, Testing and Commissioning of all Hardware, Software, Content Development for 55 inch or more Transparent OLED Digital Signage Display including appropriate Media Server/Computer Server/CPU along with all cables and display enclosure for showcasing masterpiece Objects of NM the details of which will be provided by National Museum. (Annexure I-(a)) | 6.00 | sets | | |
| 1.02 | Design, Supply, Installation, Testing and Commissioning of all Hardware, Software, Content Development for 5x2 grid thin bezel multi-touch LED Digital Display Wall using 46-48 inch LED digital signage including | 2.00 | Sets | | |

| | | | | | |
|------|---|-------|------|--|--|
| | appropriate Media Server/Computer Server/CPU along with all cables and display enclosure for interactive display of NM Objects the details of which will be provided by National Museum. (Annexure I-(b)) | | | | |
| 1.03 | Design, Supply, Installation, Testing and Commissioning of all Hardware, Software, Content Development for Large Indoor P 2.5mm LED wall with Holographic illusion (Pepper-Ghost Pyramidal Holographic display) including appropriate Media Server/Computer Server/CPU along with all cables for display of video content on National Museum and its Objects for which information will be provided by National Museum. (Annexure I-(c)) | 1.00 | Set | | |
| 1.04 | Design, Supply, Installation, Testing and Commissioning of all Hardware, Software, Content Development for Orientation Film by way of 3-Wall Projection Mapping Show using DLP Laser Phosphor Projectors with necessary lenses including appropriate Media Server/Computer Server/CPU along with all cables for giving brief information about all the galleries of National Museum, the brief write-up on which will be provided by National Museum. (Annexure I-(d)) | 1.00 | Set | | |
| 1.05 | Design, Supply, Installation, Testing and Commissioning of all Hardware, Software, Content Development and Display system for Technology Engagement for each of the 10 galleries by using any two of the listed technologies as per annexure-I(e) including appropriate Media Server/Computer Server/CPU along with all cables for giving detailed information about the masterpiece/selected Objects of the gallery, which will be provided by National Museum. (Annexure I-(e)) | 20.00 | Sets | | |
| 1.06 | Design, Supply, Installation, Testing and Commissioning of all Hardware, Software, Content Development for Central Content Device Management Software System including appropriate Media Server/Computer Server/CPU along with all cables and networking component for managing all the | | | | |

| | | | | | |
|-------------------------------|---|--------|--|--|--|
| | devices and contents that have been listed in this tender. (Annexure I-(f)) | | | | |
| Total in Figures | | | | | |
| Quoted Rate in Figures | | Select | | | |
| Quoted Rate in Words | | | | | |

(The Rate for Annual Maintenance Contract after completion of warranty Period is to be provided by the bidder)

The cost shall include System Integration & Soft commissioning of the system

Offline Financial Bid shall not be accepted under any circumstances.

ANNEXURE-D

EXPERIENCE IN CREATING DIGITAL EXPERIENCE USING MOST MODERN DIGITAL GADGETS AND TECHNIQUES AND HAVE THE PROFICIENCY IN STORY TELLING USING DIGITAL MEDIA AT MUSEUMS/ART GALLERIES/EXHIBITION/PUBLIC SPACE ETC. ON BASIS OF FINALIZATION OF AGREEMENTS EXECUTED DURING THE LAST 5 YEARS SUPPORTED BY MINIMUM THREE CREDENTIALS

Agency Experience (Private/PPP/Joint Venture/Consortium Projects)

| S. No | Name of the project | Cost of the Order awarded in INR | Name of the Client | Phone of Contact Person of Client | Starting Date of Project | Completion Date of Project | Details/ Scope of work |
|-------|---------------------|----------------------------------|--------------------|-----------------------------------|--------------------------|----------------------------|------------------------|
| | | | | | | | |
| | | | | | | | |
| | | | | | | | |
| | | | | | | | |
| | | | | | | | |
| | | | | | | | |
| | | | | | | | |
| | | | | | | | |
| | | | | | | | |

(Signature of Authorized Signatory)

FORMAT FOR AVAILABILITY OF TECHNICAL TEAM.

The bidder needs to provide the details of key personnel / support staff as proposed by him for deployment on site for successful completion of the show.

| S.No | Key personnel / support staff | Name and short bio to be given by the bidder |
|-------------|--|---|
| (a) | Team Leader | |
| (b) | Technical Expert in Digital Technology | |
| (c) | System Integration Engineer | |
| (d) | Content Creator | |
| (e) | Other Manpower | |

The bidder may co-opt experts in any other field deemed necessary.

(Signature of Authorised Signatory)

**FORMAT FOR ANNUAL TURNOVER AS PER THE AUDITED ACCOUNTS
TOWARDS THE QUALIFYING EXPERIENCE**

| S. No. | Financial Year | Turnover in Indian Rupees(INR) |
|--------|----------------|--------------------------------|
| 1. | 2017-18 | |
| 2. | 2018-19 | |
| 3. | 2019-20 | |

(In case of Consortium, the Turnover of only lead partner needs to be mentioned)

(Signature of Authorised Signatory)

This is to certify that the above information has been examined by us on the basis of relevant documents; books of accounts & other relevant information and the information submitted above is as per record and as per details annexed.

Signature, Address, Seal & Membership No of Chartered Accountant.

**NATIONAL COUNCIL OF SCIENCE MUSEUMS
SECTOR-V, BLOCK-GN, BIDHANNAGAR
KOLKATA : 700 091.**

TENDER No. I-18012/7/20(126)

DECLARATION

We do hereby accept the “Scope of Work, Bill of Quantities, General Terms & Conditions, and all other terms of the tender as provided by the National Council of Science Museums along with the Tender documents for the Supply, Installation, Integration, Testing, Commissioning and Three Years Onsite Maintenance of “Digital Experience in the Reception Hall and Orientation Hall” at National Museum, New Delhi and also under take to supply the said materials and carry out the work within the stipulated time strictly as per the Scope of work and Technical Specifications of National Council of Science Museums as provided along with the tender documents, in the event of placement of any order on us. The NCSM shall be at liberty to cancel the order in full or part, in the event of failure of the above declaration made by us and forfeit the EMD submitted by us.

Signature of the Bidder / Constituted Attorney

FORMAT FOR ARTICLES OF AGREEMENT

INSTRUCTIONS (not to be typed in Agreement)

(Articles of Agreement have to be typed on non-judicial stamp paper. The value of the stamp paper varies from state to state and is to be known from the particular place. The stamp paper will be purchased by the successful e-tenderer and the agreement may be typed by the Museum/Centre according to the format.)

ARTICLES OF AGREEMENT made at

.....

.....
.....
this..... (Place) day of

..... (Date) (Month & Year) the

between
.....

(Name of the parent Museum/Centre)

(under the National Council of Science Museums, a Society registered under the Societies Registration Act of West Bengal, 1961), hereinafter referred to as the Museum/Centre which expression shall include its successors and assigns on the one part and

(Name of the successful e-tenderer)

trading in the name and style of

(Name and complete address of the successful e-tenderer)

hereinafter referred to as the successful e-tenderer which expression shall include his/their respective heirs, executors, administrators and assigns on the other part.

WHEREAS the Museum/Centre is desirous of getting the work of
..... therein done and has caused

(Name of the work)

Notice Inviting E-tender (Including appendix), drawings, schedule of quantities and specifications describing the work and conditions of contract to be prepared by.....

.....
.....

(Name and address of the Architect).

AND WHEREAS the said NIT (including appendix) drawings as per list attached, specifications and the priced schedule of quantities and conditions of contract have been signed by or on behalf of the parties hereto. AND whereas the Successful e-tenderer has deposited in Bank Draft/Pay Order/NEFT/RTGS

.....
.....

(Exact amount in words)

the amount being 10% of the ordered value of the e-tender) with the Museum /Centre as Security Deposit for the due performance of this Agreement as provided in the said conditions.

NOW IT IS HEREBY AGREED AND DECLARED BY AND BETWEEN THE PARTIES HERETO AS FOLLOWS:

1. In consideration of the payments to be made to him as hereinafter provided the successful e-tenderer shall upon and subject to the conditions herein contained execute and complete the work within months from the date of issue of letter of intent / Work Order (as defined in the scope of work of the NIT) and as per the said drawings and such further detailed drawings as may be furnished to him from time to time and described in the said specifications and the said priced schedule of quantities along with the progress of the building work.
2. The Museum/Centre shall pay to the successful e-tenderer such sum as shall become payable hereunder at the time and in the manner specified in the said conditions.
3. Time is the essence of this agreement and the successful e-tenderer shall proceed with the work, throughout the stipulated period of this contract, strictly according to the CPM/PERT/BAR CHART attached herewith and forming a part of this agreement. At any stage during execution, if any work lags behind the target as indicated in the CPM/PERT/BAR CHART for reasons directly attributable to the successful e-tenderer, he shall pay or allow the Museum/Centre to deduct from any money due to him a liquidated damage as per Clause 11(iii) of the conditions of contract.
4. This agreement comprises the work above and all subsidiary works connected therewith, even though such works may not be shown on the drawings, or described in the said specifications or the priced Schedule of Quantities.
5. The Museum/Centre through the Engineer reserves to itself the right of altering the drawings and of adding to or omitting any item of work or of having portions of the same carried out departmentally or otherwise and such alterations or variations shall not vitiate this agreement.
6. All disputes and differences of any kind whatever, arising out of or in connection with the contract on the carrying out of works (Whether during the progress of the work or after their completion and whether before or after the determination, abandonment or breach of the contract) shall be referred to arbitration as per Clause 11(xvi) of Annexure - A of the said conditions of contract. In case of any legal dispute, other than the arbitration, the court of jurisdiction shall be at the place written in the first line of this agreement.

The provisions of the Arbitration & Reconciliation Act 1996 or any statutory modification or re-enactment thereof and of the rules made there under for the time being in force shall apply to arbitration proceedings under this clause.

In witness whereof the parties have set their respective hands the day and the year and the place hereinabove written.

Signed by for and on behalf of the Museum/Centre

.....
.....

(Controller of Administration)

In the presence of

1.
.....

Seal

(Dy Controller, Finance & Accounts)

2.
.....

(Project Co-coordinator/Engineer)

Signed by the said Successful e-tenderer

.....

In the presence of

1.
.....

Seal

2.
.....

Detailed Specifications

Annexure I – (a)

Design, Supply, Installation, Testing and Commissioning of all Hardware, Software, Content Development and Display Cases for 55 inch Transparent OLED Digital Signage Display including appropriate Media Server/Computer Server/CPU along with all cables and display enclosures for display of masterpiece Objects which will be provided by National Museum

| Sl. No | Item Description | Specification | Quantity |
|--------|--|--|----------|
| 1. | 55 inch Transparent OLED Digital Signage Display | <p>Screen Size: 55" or more</p> <p>Panel Technology: OLED</p> <p>Native Resolution 1,920 × 1,080 (FHD)</p> <p>Brightness (Typ.) 150 / 400 nit or more</p> <p>Contrast Ratio 150,000: 1</p> <p>Color Gamut BT709 or ITU709</p> <p>Viewing Angle(H × V) 178 × 178</p> <p>Color Depth 10 bit or more</p> <p>Operation Hours (Hours/Day) 12 / 7 or more</p> <p>Portrait / Landscape Yes / Yes</p> <p>Transparency 35 % or more</p> <p>CONNECTIVITY</p> <p>Input HDMI (HDCP 1.4), USB 2.0 Type A (2)</p> <p>Output DP, RS232C In/Out, RJ45</p> <p>MECHANICAL SPECIFICATION</p> <p>Bezel Width 8 / 8 / 8 / 125 mm (T/L/R/B) or less</p> <p>Protection Glass Depth 3.0 mm, Tempered, Anti-Reflective.</p> <p>Internal Memory 64 GB or more</p> <p>Sync Mode RS-232C Sync, Local Network Sync</p> <p>ENVIRONMENT CONDITIONS</p> <p>Operation Temperature 0 °C to 60°C or better</p> <p>Power Supply AC 220 - 240 V , 50 Hz</p> <p>Power Type Built-in Power</p> <p>CERTIFICATION BIS certification, BIS registration</p> | 6 (Six) |
| 2. | Content Development | <p>The SI will draft the detailed narration script, Dialogue script, Visual story board on the provided theme for individual displays (total eight). Content should be based on the artefact or masterpiece and having introductory visual story.</p> <p>The SI requires to develop a content, based on a narration script with design and artwork, sound effects and animation and VFX. The theme of the story will be provided in due course of time. The SI should take care of visual story board, editing , rendering, casting, voice over, shooting direction, motion graphics, 2d/3d animation etc. for the development of the movie. The detail</p> | |

| | | | |
|----|---------------------------|--|--|
| | | <p>visual storyboard should be required to approve from the competent authority. The SI should give the audio track separately with video files.</p> <p>A tentative spec:</p> <p>Time duration for the content /video 5 minutes Resolution FHD or higher Language English/Hindi (Bilingual)</p> | |
| 3. | Display enclosures | As required at the site | |
| 4. | Accessories | Remote Controller, Power Cord, QSG, IR Receiver, Regulation Book, Phone to RS232C Gender, all required cables and accessories including shield cover, tape and Damper if any to install and connect the system from the CCC. | |
| 5. | Software compatibility | Should be interlinked with the CCC application as stated in item Annexure – I (g) and can be monitored remotely. | |

Design, Supply, Installation, Testing and Commissioning of all Hardware, Software, Content Development and Display Cases for 5x2 grid thin bezel multi-touch Interactive LED Digital Display Wall using 46-48 inch LED digital signage including appropriate Media Server/Computer Server/CPU along with all cables and display enclosures for interactive display of masterpiece Objects the details of which will be provided by National Museum

Job Description:

The indoor video wall will be with a matrix of 5(Column) and 2 (Row) with a color depth of 8 bit or more and LED lit LCD panel technology. Each panels in the matrix will be 46'' or 48'' in diagonal and arranged in a format so that the brightness and intensity will be uniformly distributed to the entire video wall. The SI should provide the cabinet drawing, mechanical drawing for their intended cabinet and Frame kit, Data flow diagram, Power flow diagram.

At a minimum this shall include the following:

- a. Finger touch based Interactive video wall as per required specifications
- b. Interactive multi-user video wall management Software: Many people use the touch wall simultaneously. The apps can show up to 2000 or more files such as pdfs, videos and images etc. Those files can be manipulated in multi-touch by all the users simultaneously. The software has the functionality to scatter the images or animated frames or graphics to the entire display. Visitors can send some images or frames upon providing their email address. The software has the CMS system where the administrator configured the resource files and add content in the form of images, videos or pdf etc. These files are updated accordingly in the display.

The Mounting cabinet and aluminium framing for the indoor interactive video wall at the designated place. The broad scope of work for the SI during the period of contract/ engagement would include Supply & Installation of Video wall and its integrated system with Command and Control Centre (CCC) with three years support and maintenance. Bidder should provide the cabinet drawing, mechanical drawing for their intended cabinet and Frame kit, Data flow diagram, Power flow diagram.

| Sl. No | Item Description | Specification | Quantity |
|--|---|---|--|
| Technical Specification for Interactive Video wall | | | |
| The indoor video wall will be with a matrix of 5(Column) and 2 (Row) with a colour depth of 8 bit or more and LED lit LCD panel technology. Each panels in the matrix will be 46'' or 48'' in diagonal and arranged in a format so that the brightness and intensity will be uniformly distributed to the entire video wall. | | | |
| 1. | 5x2 grid thin bezel multi-touch LED Digital Display Wall using 40-42 inch LED digital signage | Bezel Size and scan rate: Resolution per panel: Aspect Ratio: Brightness: Contrast: | Bezel less or Bezel size less than 1.8 mm (including two) with backlight scanning rate/ frame rate must be 60Hz or more 1920 X 1080 or more (native resolution) 16:9 500 cd/m ² or nits or higher for daylight 4000:1 or greater in normal |
| | | | 2 (two) set |

| | | | |
|---|--|--|--|
| | | <p>Backlight mode LED with 50000 hours' lifetime or more</p> <p>Viewing angle 178/178 (H X V) or greater</p> <p>Color and brightness adjustment: Each LCD panels will be equipped with sensors permitting the brightness level of each LED backlight to be controlled and adjusted automatically. Brightness of the wall and each panels can also be controlled form the control management software provided with the video wall.</p> <p>Input signal Panels shall be HDMI inputs supporting to HD resolution or higher at 30 fps or higher.</p> <p>Connectivity 2 nos. HDMI, USB and LAN port RJ45 2 nos, RS232 etc.</p> <p>Redundant power supply Yes</p> <p>Maintenance The panel can maintain from the front end and Mount allows both portrait and landscape orientations. The LCD panel will slide into X,Y,Z axes. All individual panels are easily accessible from the front - even the middle panels. Each panel can be taken out swiftly and securely, making and maintenance easier. Moreover, cabling and electronics can also be pre-tested before screen installation.</p> <p>Video wall Controller (VC) All video signals can be sent to video wall using a single video cable connection from the controller.</p> <p>Panel width with module 200 mm or less</p> | |
| <p>Video Controller Technical specification A configurable system to meet the interactive LED Wall</p> | | | |

| | | | | |
|------------------------------------|------------------|---|--|-------|
| 2 | Video Controller | <p>Operating System</p> <p>Chassis</p> <p>CPU</p> <p>GPU</p> <p>RAM</p> <p>RAID</p> <p>Hard Disk</p> <p>Cooling</p> <p>Network</p> <p>Indicators</p> <p>Resolution Support</p> <p>Format</p> <p>Redundancy support</p> <p>Display :</p> | <p>Windows 10 64-bit IoT Enterprise or higher, Professional/ Home/ Embedded or professional as required by the installation of the interactive video wall</p> <p>19'' industrial rack mount, lockable front door to protect drives</p> <p>Xeon i7 six Core / AMD Thread ripper based server 3.0 GHz or higher</p> <p>NVIDIA GeForce GDDR5 12GB or equivalent max resolution 4096x2160 @ 60 Hz</p> <p>16 Gb DDR4 or more</p> <p>0, 1, 5, 10 support</p> <p>R.A.I. D-1 redundant setup with 2x 1000GB 2.5'' HDD Hard disk</p> <p>Dual Fan for cooling</p> <p>Dual port Gigabit Ethernet controller inbuilt 1Gb/s or more</p> <p>LED's for HDD activity and power status</p> <p>4K, HD, QHD</p> <p>H.264, H.263 or custom format</p> <p>Power supply, HDD, cooling Fan, LAN Port</p> <p>23''/24'' Flat panel LED Monitor with HDMI display port</p> | 2 set |
| Touch overlay Specification | | | | |
| 3 | | <p>Touch overlay size:</p> <p>Glass</p> <p>Touch points</p> <p>Touch Technology</p> <p>Touch method</p> <p>Construction</p> <p>Finger Touch Accuracy</p> <p>Touch Response Time</p> | <p>205'' or as required by the total size of the video wall as per matrix and mentioned specification of video wall.</p> <p>3mm or more tempered glass with hardness 7H or better. oleophobic coating and scratch resistance is desirable</p> <p>40 or more</p> <p>Infrared / Capacitive</p> <p>Finger, Stylus</p> <p>Sturdy, metal or ABS materials or equivalent</p> <p>+1.5 mm or less</p> <p>13 ms or less</p> | 2 set |

| | | | | |
|--|-------------------------|--|--|--|
| | | Multi-Overlay support OS capability Certification Power supply USB extender Features: Protection | yes as required by the Video controller FCC, CEE, RoHS, IP65 or BIS etc. Single USB Connection Power extends high-speed USB 2.0 connections up to 100 m using CAT 5e/6/7 as required for the integration of touch overlay, keyboard and mouse. Gesture like tap, swipe, zoom-in may be added features. Whole interactive display should be protected from Toughened or Tempered Glass so that finger touch pressure do not affect the LCD panel. | |
| Environment Condition for Interactive video wall, Controller and others | | | | |
| | Environmental Condition | Acoustic Noise Operation Temperature 0 °C to 60°C Power Supply CERTIFICATION | LCD and VC Max. 50dbA or less (measured at 1m/3.28ft distance at 22°C/72°F) AC 2200 - 240 V ~, 50 Hz with on/off switch BIS certification, BIS registration | |
| 4. | Apps development | Interactive multi-user video wall management Software as specified above | | |
| 4. | Display enclosures | As required by the site | | |
| 5. | Accessories | Installation of the hardware and software as required by the site and demand of the project, wiring of the power, HDMI and Cat6 cable and any controller as demand by the site installation. | | |

6

Ref Diagram

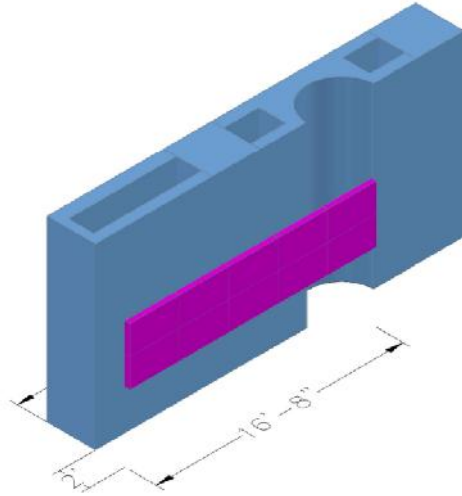

Design, Supply, Installation, Testing and Commissioning of all Hardware, Software, Content Development and Display Cases for Large Indoor P 2.5mm LED wall with Holographic illusion (Pepper-Ghost Pyramidal Holographic display) including appropriate Media Server/Computer Server/CPU along with all cables and display enclosures for display of video on masterpiece Objects which will be provided by National Museum

Job Description

A system comprises of LED video wall, LED controller and Holographic illusion is required to setup in the gallery. The display or content is going to be controlled by the Command and Control Centre (CCC). The SI requires to develop a content, based on a narration script with design and artwork, sound effects and animation and VFX. The theme of the story will be provided in due course of time. The SI should take care of visual story board, editing, rendering, casting for the development of the movie. The detail visual storyboard should be required to approve from the competent authority.

1. The supply and installation of indoor video wall integrated with the holographic illusion system at National Museum, Delhi.
2. The supplier will have to provide minimum 3-years onsite warranty for the product supplied with the complaint resolution time of maximum 72 hrs. from the time of lodging of complaint.
3. SI shall ensure that all the supplied items are properly fixed as per Indian Standards applicable. SI shall be responsible for any mis-happening, casualty, damage, loss of lives, goods and shall get the Video wall repaired & re-installed in its original working condition.
4. The hardware should be supplied with all the required installation material/ accessories (wherever required) for proper installation at respective site.
5. Purchaser shall provide power connection with proper load capacity till electricity Meter or electrical point of the Video Wall beyond which SI shall be responsible for all electric connection including cabling & its casing/ laying/ trenching, MCB (as required) connection along with its secure housing, cabling (4 core 10 square mm copper cable) & casing till the Rack behind Video wall, appropriate Earthing and any other component required for successful commissioning of the video wall.
6. The software supplied should be of genuine OEM license.
7. The SI shall be responsible to provide any other material required for successful commissioning of the Video Walls.
8. Officials from National Museum, Delhi or competent authority upon receipt of delivery challan of all the ordered items as per prescribed time schedule, may inspect the supplied items during the respective delivery to validate them in compliance with the work order or Purchase order.
9. Upon successful installation (wherever applicable) of all the supplied Hardware/ Software, the SI shall submit installation reports (in original) duly verified by the respective person from National Museum, Delhi or competent authority.
10. The content on the video wall should be centrally managed as well as should have provision of locally management of the same.
11. The Video Wall display unit should be capable of auto power (electric) On/Off on the pre-defined time slots.
12. The offered led video wall should have automatic brightness control.
13. **The SI should provide the cabinet drawing, mechanical drawing for their intended cabinet and Frame kit, Data flow diagram, Power flow diagram.**

The product should have more than 5 years life spans from the date of Procurement.

| Sl. No | Item Description | Specification | Quantity |
|--------|-------------------------------|---|-------------|
| 1. | Large Indoor P 2.5mm LED wall | <p>Display Wall Dimension 11 X 12 ft (approx.)</p> <p>Display Area 131 ft² (approx.)</p> <p>Resolution 4 K (Minimum)</p> <p>Power consumption 5400 watts max. or less</p> <p>Pixel Pitch 2.5mm</p> <p>Brightness: 1200 NIT or higher</p> <p>Diode type SMD</p> <p>Contrast Ratio 5000:1</p> <p>Viewing Angle 160 X 160 (HX V) or more</p> <p>Bit Depth 16 bit</p> <p>Frame rate 50 Hz or more</p> <p>Input power Range 100-240 VAC, 50/60 HZ</p> <p>Power Consumption 2500 Watt for the video wall</p> <p>IP rating IP20</p> <p>LED Lifetime 50000 hours or more</p> <p>Maintenance Service Front and full aluminum construction</p> <p>Maintenance The panel can maintain from the front end and Mount allows both portrait and landscape orientations. The LCD panel will slide into X,Y,Z axes. All individual panels are easily accessible from the front - even the middle panels. Each panel can be taken out swiftly and securely, making and maintenance easier. Moreover, cabling and electronics can also be pre-tested before screen installation.</p> <p>Framing Aluminium construction or light alloy (rust proof)</p> <p>LED controlling hub LED Controlling unit should control the video display on video LED wall</p> <p>Protective function Over heat/ Over-load/ Power-down/ power- leakage / Lighting protection etc.</p> <p>Certification BIS, EMC Class A, Safety 60950-1, FCC, UL, CB</p> | 1 (One) Set |
| | Hologram display with stand | <p>Screen size 55"</p> <p>Resolution 3840 X 2160 or higher</p> <p>Viewing Angle 178 X 178</p> <p>Aspect Ration 16:9 or 10</p> <p>Terminals HDMI, RGB, Rj- 45 , RS232</p> <p>Auto Brightness Sensor yes</p> <p>Internal Memory 8 Gb or 16 GB</p> | |

| | | | |
|----|----------------------------------|---|--|
| | | <p>Wi-fi 802.11n combo built-in</p> <p>Operation Hours (Hours/Day) 18 / 7 or 24/7</p> <p>Portrait / Landscape Yes / Yes</p> <p>Protection Glass 3.0 mm, Tempered / Chemical Strengthening, Anti Reflective, Shatter-Proof</p> <p>Holographic pyramid glass structure Material: Toughened glass, Dimension as required by the structure or site, Bronze tinted glass or similar, transimitivity: 70%, thickness: 6 mm or less</p> <p>Operation Temperature 0 °C to 60°C or better</p> <p>Power Supply AC 220 - 240 V ~, 50 / 60 Hz</p> <p>Power Type Built-in Power</p> <p>CERTIFICATION BIS certification, BIS registration</p> | |
| 2. | Computer System and graphic card | <p>Operating System Windows 10 64-bit Professional/ Home/ Embedded or professional as required by the installation of the interactive video wall</p> <p>Chassis 19" industrial rack mount, lockable front door to protect drives</p> <p>CPU Xeon i7 six Core / AMD Thread ripper based server 3.0 GHz or higher</p> <p>GPU NVIDIA Quadro GDDR5 8GB graphics card</p> <p>RAM 16 Gb DDR4 or more</p> <p>RAID 0, 1, 5, 10 support</p> <p>Hard Disk R.A.I. D-1 redundant setup with 2x 1000GB 2.5" HDD Hard disk</p> <p>Cooling Dual Fan for cooling</p> <p>Network Dual port Gigabit Ethernet controller inbuilt 1Gb/s or more</p> <p>Indicators LED's for HDD activity and power status</p> <p>Resolution Support 4K, HD, QHD</p> <p>Format H.264, H.263 or custom format</p> <p>Redundancy support Power supply, HDD, cooling Fan, LAN Port</p> <p>Display : 23"/24" Flat panel LED Monitor with HDMI display port</p> | |
| 3. | Content Development | <p>The SI will draft the detailed narration script, Dialogue script, Visual story board on the provided theme for the display which is shown in an attractive and appealing format to the visitor with combining display of LED wall and Holographic pyramid. Content should be based on the artefact or masterpiece and having introductory visual story. The content is narrated in</p> | |

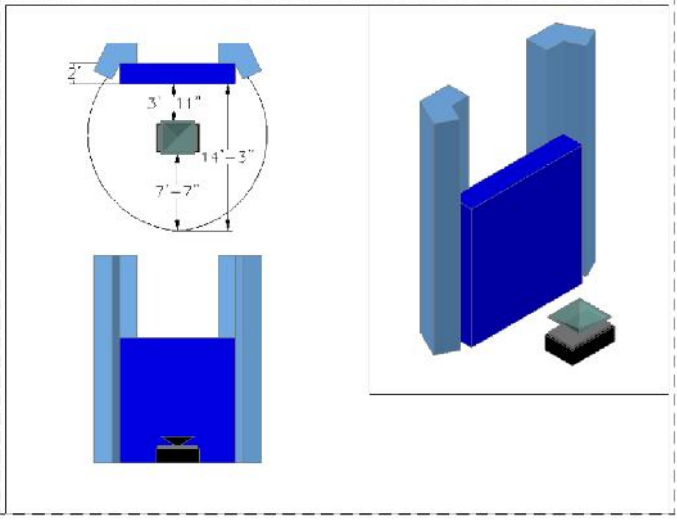
| | | | |
|----|-------------|--|--|
| | | <p>such a way that it can be distributed in time lapse manner with holographic system and LED wall.</p> <p>The SI requires to develop a content, based on a narration script with design and artwork, sound effects and animation and VFX. The theme of the story will be provided in due course of time. The SI should take care of visual story board, editing , rendering, casting, voice over, shooting direction, motion graphics, 2d/3d animation etc. for the development of the movie. The detail visual storyboard should be required to approve from the competent authority. The SI should give the audio track separately with video files.</p> <p>A tentative spec:</p> <p>Time duration for the content /video 5 minutes Resolution FHD or higher Language English/Hindi (Bilingual)</p> | |
| 5. | Accessories | Installation of the hardware and software as required by the site and demand of the project, wiring of the power, HDMI and Cat6 cable and any controller as demand by the site installation. | |
| | Ref drawing |  | |

Annexure – I-(d)

Design, Supply, Installation, Testing and Commissioning of all Hardware, Software, Content Development and Display Cases for Orientation Film by way of 3-Wall Projection Mapping Show using DLP Laser Projectors with necessary lenses including appropriate Media Server/Computer Server/CPU along with all cables and display cases for giving brief information about all the galleries of National Museum, the brief write-up on which will be provided by National Museum

The SI should provide the system workflow, mechanical drawing for their intended cabinet and Frame kit, Data flow diagram, Power flow diagram.

Quantity : 1 set

| Sl. No. | Items | Specification | Quantity |
|---------|------------------|---|------------------|
| 1 | Laser projectors | Projection Method: Ceiling mount Brightness: 7500 Lumens or more Lamp Life: 20,000 hrs. Resolution: WUXGA (1920 x 1200) Throw distance: as per site condition Aspect ratio: 16:9-10 Contrast Ratio: 300000:1 or more Display Technology: DLP Lamp Type: High efficiency Laser Phosphor Lens Shift: Horizontal & Vertical Digital Keystone: Horizontal & Vertical Inputs: HDBaseT, HDMI, DVI-D Throw ratio: 0.4 or less or as required by the site condition Terminals: HDMI, DVI-D, RS 232c Complaint port, LAN RJ-45 network link RGB In with BNC, USB DVI Digital Input Audio In (Mini Jack) VGA Out (Dsub-15pin) Lens Shift (Standard lens) Horizontal: ±30 degrees/Vertical: ±40 degrees or more Brightness Uniformity: (typical) 90% or better Special Features: Operation of 24/7 should be possible, Edge Blending, Geometric Correction (built-in), portrait projection mode without switching lamp Warranty: 3 YEARS ONSITE Make: Barco, Christie, Panasonic or equivalent approved Please quote the number of projectors after carefully understanding the site conditions, the number and sizes of the surfaces to be mapped and the scope for installation of projectors. Also, submit the sketch proposing the placement of the projectors during your technical presentation. It is highly recommended to visit the site before quoting. | 3 (Three) |

| | | | |
|---|-------------------------------------|---|---|
| 3 | Primary media server | <p>Intel i7 Processor / AMD thread ripper or equivalent Window 10 pro OS (With lifetime license) with 16GB RAM or more Nvidia GPU with minimum 4 outputs supporting 7680x4320@60Hz 256 GB SSD primary drive 256 GB SSD secondary drive Motherboard supporting 1 gpu at x16 Full HD output on each display out 23/24 " Flat Panel LED Monitor with HDMI or equivalent display port Industrial grade components from high end brands like Asus, MSI, Gigabyte, corsair, coolermaster This mapping system needs to be designed to create an integrated projection mapping show with 2 or more wuxga projectors edge blended together Backup Media Server, if required Warranty: 3 Yrs. Onsite Make: I7 or thread ripper based Server</p> | 1 |
| 4 | Backup media server | <p>Intel i7 Processor / AMD thread ripper or equivalent · Window 10 pro OS (With lifetime license) · 16GB RAM or more Nvidia GPU with minimum 4 outputs supporting 7680x4320@60Hz 256 GB SSD primary drive 256 GB SSD secondary drive Motherboard supporting 1 gpu at x16 Full HD output on each display out 23/24 " Flat Panel LED Monitor with HDMI display port Industrial grade components from high end brands like Asus, MSI, Gigabyte, corsair, coolermaster This mapping system needs to be designed to create an integrated projection mapping show with 2 or more wuxga projectors edge blended together Backup Media Server, if required Warranty: 3 Yrs. Onsite Make: I7 or thread ripper based Server</p> | 1 |
| 5 | Projection mapping software license | <p>Unlimited Video layers /blocks Window 10 pro OS compatible DMX/Artnet protocol compatible WUXGA multiple Video Playback Support for 2 or more Projectors MIDI/OSC Show control. Multi-Channel Audio. Ethernet based IP control system to switch between primary and backup server. Make: Coolux, Madmapper, Resolume, Watchout, Disguise D3 or Indiginious. Lifetime software license validity.</p> | 2 |
| 6 | HDMI Extender receiver/transmitter | <p>Should be able to transmit and receive signals distance ranging from 300 to 600 feet Make: Black magic, Design, Kramer, Extron</p> | 3 |
| 7 | Network | <p>16 port managed switch with 1000 mbps speed</p> | 1 |

| | | | |
|----|--|---|---|
| | Switch | Make: Cisco, Netgear or equivalent approved | |
| 8 | Show control system | Ethernet based ip control system to trigger the show through an iPad, control signals to the projectors, light control communication support for Ethernet, RS-232/422/485, IR/Serial, DMX, iPhone, iPad, Android control app support, Physical push buttons Make: Crestron, Extron, Krammer, | 1 |
| 9 | Ipad/android tablet | Show control application compatible Make: Apple, Samsung or equivalent approved | 1 |
| 10 | Wi-Fi router | 802.11ac based router with high speed of 300 mbps Make: Cisco, Netgear or equivalent approved | 1 |
| 12 | Sound System Processor & Speaker array with woofer | Audio system shall consist of speakers and subwoofer mounted suitably in the visitors area. Make: Bose, Electro voice, JBL, Yamaha | 1 |
| 19 | Projector clamps | Projector clamps | 3 |
| 14 | Cables for Video Data transmission | Cables for data transmission needs to of robust quality, to withstand and climatic condition. Cables should be able to withstand any electromagnetic interference in presence of any. Make: Cisco, Linksys or equivalent approved | 3 |
| 15 | Projector control cable | UTP CAT 6 | 3 |
| 16 | Power cables for projectors | 3Core Hard bound cables which can withstand any climatic or time based challenges | 3 |
| 17 | Server Rack | Should be able to hold all the servers and amps inside and should have a lock for security | 1 |
| 18 | Fabrication | 2"x2" teakwood in 2'x2' grid as base and 12mm BWP anti termite "A" grade ply of Century or Green make on top of frame, duly finished with putty, primer and ScreenGoo projection paint | 3 |
| 19 | DMX artnet lights control | DMX controller system for controlling general illumination of hall | 1 |
| 20 | Integration | Integration of project | 1 |

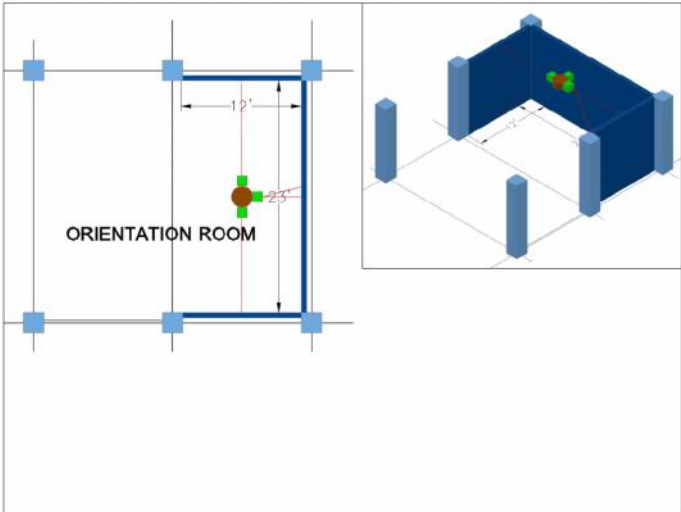
| | | | |
|----|-------------------|--|---|
| 21 | Content | <p>Creative Concept Note Narration Script Dialogue Script Visual Storyboard Creative Visual Direction Design & Artwork (Including photos & Videos & Illustrations) Music Composition & arrangement (Including musicians, instruments, singers, chorus artists) Sound Effects Sound Mixing 2D Animations 3D projection Animations Motion graphics Visual Effects (VFX) Voice Over recording supervision (Including Voice Over Artists in Single Language) Editing Rendering as per media server formats Shoot Direction & Management (Including Location shoot, green screen Setup) (Including Shoot equipment - Camera, lights, sound) (Including Technical crew) Casting (Including Actors, Performers) (Including Costumes, props, setting)</p> | 1 |
| 22 | Reference Drawing |  | |

Actual Size of the Video Wall may vary depending upon Site conditions, design and functional need. The bidder may need to visit the site for assessing the need.

Annexure – I-(e)

Design, Supply, Installation, Testing and Commissioning of all Hardware, Software, Content Development and Display Cases for Technology Engagement for each of the 10 galleries by using any two sets (one from each group) of the listed technologies for each gallery including appropriate Media Server/Computer Server/CPU along with all cables and display enclosures for giving detailed information about the masterpiece Objects of the gallery, which will be provided by National Museum. (Any two of the technologies mentioned from SI No. 1 to 12 or any other similar latest technology)

The SI will develop 20 sets of the below listed technologies (two different sets for each gallery) with applications in a bilingual format, **two each for the 10 galleries**. The themes of the galleries are Harappan Civilisation (1 gallery), Sculpture (4 gallery), Decorative Arts (2 Gallery), Textiles (1 gallery), Jewellery (1 gallery), Painting (1 gallery) . The SI can get details of these themes from NM website. The SI should try to use all the listed technologies in different galleries by choosing different combinations.

The SI requires to develop the application with content, based on a narration script with design and artwork, sound effects and animation and VFX. The theme of the story will be provided in due course of time. The SI should take care of visual story board, editing, rendering, casting, voice-over, shooting direction, motion graphics, 2d/3d animation etc. for the development of the application. The detailed visual storyboard and mode of display or technology should be required to approve from the competent authority.

The SI should choose Exhibit technology from the following list. The list is not exhaustive and can be proposed by SI with more immersive technology. The SI will do design development, software development, exhibit fabrication etc. However, The SI will require to implement at least VR and AR technology, Multi-touch (55’’) kiosk and Interactive timeline, etc.

The SI should provide the complete details of each exhibit and its mode of display, the technology used, Hardware specification, storyboard, etc.

The technologies chosen by the SI for any of the galleries may be changed after the discussion with NM/NCSM without any change in the overall cost. The payment will be made based on the total number of sets (out of 20) finally used in the gallery on pro rata basis.

| Sl. No | Item Description | Specification and scope of work | Quantity |
|--------|--|---------------------------------|---------------------------|
| | Group A | | |
| 1. | AR Wall. App with image recognition | Annexure – I-(e).1 | To be given by the Bidder |
| 2. | Pillar mounted, fixed station type multiple Virtual Reality/ Mixed Reality content | | |
| 3. | Eyeball tracking based digital interaction | | |
| 4. | AI based Interaction with digital presence of famous personality | | |
| 5. | Pepper-Ghost Holographic Display | | |

| | | | |
|-----|---|--|--|
| | Group B | | |
| 6. | Multi-touch Kiosk Station | | |
| 7. | Interactive Kiosk with 3D scanned object content | | |
| 8. | Linear Seamless Visual Seeker with touch interactive screen | | |
| 9. | Virtual Presenter | | |
| 10. | Projection based digital flip book | | |
| 11. | Interactive Touch projection Wall | | |

Annexure – I-(e).1

| Sl. No | Item Description | Specification and scope of work | Quantity |
|--------|-------------------------------------|--|--------------------|
| 1. | AR Wall. App with image recognition | <p>Equipment:</p> <p>1. Projector</p> <ul style="list-style-type: none"> • 5000 ANSI Lumen DLP Laser based projector (Ceiling mount) • Throw Ratio 0.5 or as required at site • Lamp life: 20000 hrs. or more • Resolution : 1920 X 1080 • Lamp type: Laser • Lens Shift Horizontal: ±30 degrees/Vertical: ±40 degrees or more • Terminals: HDMI, DVI-D, RS 232C Complaint port, LAN RJ-45 network link RGB In with BNC, USB DVI Digital Input Audio In (Mini Jack) VGA Out (Dsub-15pin) • Keystone : yes, projector mount : Yes • Aspect Ratio: 16:9/10 • Warranty: 3 yrs. on site with labor/ parts and maintenance. <p>2. Minicomputer for display of projection with the projector</p> <p>3. UPS : 2KVA with cabling casing with the projector and other electrical points</p> <p>4. Application: App (bilingual language) (Android, iOS and Windows). The app will be in server-client architecture.</p> <p>Scope of Work:</p> <p>An app is required to develop in server-client architecture. The server-side content of the app will be deployed in the local server (here in the CCC). The user needs to download the apps from the local Wi-Fi or play store. A collage of artefact or graphic composition in a storyline format is projected on a wall (AR Wall). The projection of the graphic will be done via an URL that is fetched from CCC.</p> <p>Users open the apps in his/her phone/tablet and scan the picture. The apps will recognize the image and will display further information (augmented information in the form of text/video/3-D model/ animation) on the tablet. The content (Extended) is dynamically loaded</p> | 1 Set is one unit. |

| | | | |
|----|--|--|---|
| | | <p>from the server on the user display. The apps should be lightweight and consume less memory of the tablet or smart device. Visitors can Zoom-in/out and navigate the pop-up details of the artifact.</p> <p>The CMS for the app at the server-side can be used to update the content in sync with AR wall graphics.</p> <p>The apps will contain the augmented description of at least 30 artifacts or AR target images. NM Delhi will provide the artifact list and extend its cooperation for 3D scanning and other details.</p> <p>NM Delhi will provide the theme. The SI will develop the storyline, animation, scripting, and application. The SI should present their concept in technical presentation.</p> | |
| 2. | Pillar mounted, fixed station type multiple Virtual Reality/ Mixed Reality content | <p>Equipment :</p> <ol style="list-style-type: none"> 1. A virtual HMD (fully standalone device) powered with Snapdragon 821 or higher processor, Resolution 1280 X 1440 or higher, 3 gb or more RAM, FoV: 100 or more 2. A pillar with mounting device with charging cable as required by the site 3. UPS and power distribution as required at site 4. A bilingual apps for HMD <p>Scope of Work:</p> <p>An HMD will be mounted on an aesthetic rugged pillar. The visitor will put his head near HMD and can navigate the objects in the gallery with 360⁰ rotation. The HMD will be rotated on the XY-axis. The user will get the option to choose language first and then proceed further. Each station should have at least 25 hotspots. The no. can be changed according to the site condition.</p> <p>The HMD will be charged on fitted with the pillar. Protection, Design, Safety, and Hygienic of the HMD should be taken care of during the final installation.</p> <p>NM Delhi will provide the theme. The SI will develop the storyline, animation, scripting, and application. The SI should present their concept</p> | One set will comprise of 4 Fixed station in a gallery with various theme. |

| | | | |
|----|-----------------------------------|--|--|
| | | in technical presentation. | |
| 3. | Multi-touch Kiosk Station | <p>Equipment:</p> <ol style="list-style-type: none"> 55'' or more multi touch Display with proper mounting table <ul style="list-style-type: none"> Touch interface: projected Capacitive touch Touch : Finger Simultaneously Touch points: 60 or more Mounting kit Power backup : UPS as required Power Cabling and other connectivity as required at site Computer system: as required to deploy and smooth functioning of the application and integration. 4 or more Headphones (noise cut) are mounted with tables with proper holding kit. UPS and power distribution as required at site A bilingual Application <p>Scope of Work:</p> <p>An app is required to be developed on the theme of historical timeline or events or evolution from the past etc. The theme of apps will be provided by the NM Delhi. Users can navigate with the multimedia with Zoom in/ out, swipe, tap, rotation, etc. The apps will contain 2D/3D animation, motion graphics and visual effects to make the content design immersive and attractive.</p> <p>NM Delhi will provide the theme. The SI will develop the storyline, animation, scripting, and application. The SI should present their concept in technical presentation.</p> | One set will comprise of 2 units and 2 different applications. |
| 4. | Interactive Touch projection Wall | <p>Equipment :</p> <ol style="list-style-type: none"> Projector <ul style="list-style-type: none"> 5000 ANSI Lumen DLP Laser based projector (Ceiling mount) Throw Ratio 0.5 or as required at site Lamp life: 20000 hrs. or more Resolution : 1920 X 1080 Lamp type: Laser Lens Shift Horizontal: ±30 degrees/Vertical: ±40 degrees or more Terminals: HDMI, DVI-D, RS 232C Complaint port, LAN RJ-45 network link | One set will comprise of 2 projectors and two various reliefs works on different theme |

| | | | |
|----|--|---|--|
| | | <p>RGB In with BNC, USB DVI Digital Input Audio In (Mini Jack) VGA Out (Dsub-15pin)</p> <ul style="list-style-type: none"> • Keystone : yes • Aspect Ratio: 16:9/10 • Warranty: 3 yrs. on site with labor/ parts and maintenance. <p>2. Computer system: as required to deploy and smooth functioning of the application and integration. 4 or more Headphones (noise cut) are mounted with tables with proper holding kit.</p> <p>3. Sound system and UPS with cabinet as required at site. Cable dressing and placing of CPU, projector mounting kit and others will be done by SI</p> <p>4. Physical dummy object are kept with in scale down model or with low relief, high and sunken relief. The size of the display will be 12' X 8' or as site requirement.</p> <p>5. Bilingual Application</p> <p>Scope of Work: Visitor when touching any relief object, an animation projected surrounding the contour of the relief object will appear with sound video or text animation. Whenever the user touches another object it stops the previous and plays the current one. There will be at least 12 objects in the interface area. The visitor can choose the narration if any with a physical key for language selection in front of the exhibit. The aesthetic design should be intact with the physical world to the virtual world and should be complementing each other.</p> <p>NM Delhi will provide the theme. The SI will develop the storyline, animation, scripting, and application. The SI should present their concept in technical presentation.</p> | |
| 5. | Interactive Kiosk with 3D scanned object content | <p>Equipment:</p> <p>1. 55'' or more multi touch Display with proper mounting table</p> <ul style="list-style-type: none"> • Touch interface: projected Capacitive touch • Touch : Finger • Simultaneously Touch points: 60 or more • Mounting kit • Power backup : UPS as required • Power Cabling and other connectivity as required at site <p>2. Computer system: as required to deploy and smooth functioning of the application and</p> | One set will comprise of two units of interactive kiosk with 3D scanned object |

| | | | |
|----|---|---|---|
| | | <p>integration. 4 or more Headphones (noise cut) are mounted with tables with proper holding kit.</p> <p>3. A bilingual Application</p> <p>4. UPS and power distribution as required at site</p> <p>Scope of Work:</p> <p>An app is required to be developed on the theme of historical artifacts. The Artifact is required to have 3-D scanned with any techniques like photogrammetry / LIDAR etc. The apps have 3D containers for displaying the 3D scale-down objects where visitors can interact with an artifact and can understand its past, its significance and the historical importance. By zooming-in visitors can also study the art pattern or artistic impression minutely with the artifact involved. SI should scan at least 20 objects for each set. The scanning of the artifact will be done under the supervision of NM Delhi abiding by all the precautions for scanning the artifact.</p> <p>Timeline or events or evolution from the past etc. The theme of apps will be provided by the NM Delhi. Users can navigate with the multimedia with Zoom in/ out, swipe, tap, rotation etc. The apps will contain 2D/3D animation, motion graphics and visual effects to make the content design immersive and attractive.</p> <p>NM Delhi will provide the theme. The SI will develop the storyline, animation, scripting, and application. The SI should present their concept in technical presentation.</p> | |
| 6. | Linear Seamless Visual Seeker with touch interactive screen | <p>Equipment:</p> <p>1. 32'' or more multi-touch display</p> <p>2. A railing guide for holding the monitor</p> <p>3. An interface like rotary encoder or imaging device for sensing seamless navigation.</p> <p>4. Computer system: as required to deploy and smooth functioning of the application and integration. 4 or more Headphones (noise cut) are mounted with tables with proper holding kit.</p> <p>5. Bilingual application</p> | One set will comprise of three units of Linear seamless visual seeker |

| | | | |
|----|--|--|---|
| | | <p>6. UPS and power distribution as required at site</p> <p>A setup with Touch display 24'' or more will be slid horizontally / vertically by visitors on a railing track. A Visual of the relative theme will be available behind the display. The system senses the position of the touch display and provides opportunities for in-depth navigation of the particular area through the touch display. The story have 20 hotspots in-depth with immersive content on a visual theme.</p> <p>NM Delhi will provide the theme. The SI will develop the storyline, animation, scripting, and application. The SI should present their concept in technical presentation.</p> | |
| 7. | AI based Interaction with digital presence of famous personality | <p>Equipment :</p> <ol style="list-style-type: none"> 1. 55'' Display kiosk with vertical stand 2. Computer system: as required to deploy and smooth functioning of the AI application and integration. 3. Bilingual Application <p>Scope of Work:</p> <p>An AI-powered Kiosk that demonstrates a famous historical personality. The application will give an impression to make alive the famous late personality. There will be 5 videos on the personality which the famous personality himself or herself demonstrating about the era or an event or his/her life cycle. The visitor can change the content with a switch. The video may be based on deep fake technology and supported by a voice acting agent. The personality should hyper-realistically be animated with AI in order to reproduce the personality's likeness, lip movement, eyes, and eyebrows and face movement. In the end, the AI personality will take a selfie with the visitors with virtual mobile setand show it to the visitors. It can be sent to the visitor by mail if the visitor shares the email A Brief voice recognition module in the application may initiate the process.</p> <p>NM Delhi will provide the theme. The SI will develop the storyline, animation, scripting, and application. The SI should present their concept in technical presentation.</p> | One set will comprise of 5 videos on the personality. |

| | | | |
|----|----------------------------------|---|--|
| 8. | Pepper-Ghost Holographic Display | <p>Equipment :</p> <ol style="list-style-type: none"> 1. Display: 32’’ or more 2. Computing machine 3. Application on motion graphics with/without audio 4. UPS and power distribution as required at site <p>Scope of work:</p> <p>The holographic display of having a physical object or real environment mixed with the three –dimensional digital overlay. The content will be developed on a theme that gives a visual experience and catches the attention of the visitor. The holographic display can be seen by all around the physical set up or can be seen from three sides of the exhibit.</p> <p>NM Delhi will provide the theme. The SI will develop the storyline, animation, scripting, and application. The SI should present their concept in technical presentation.</p> | one set will comprise of five Pepper-Ghost Holographic Display |
| 9. | Virtual Presenter | <p>Equipment :</p> <ol style="list-style-type: none"> 1. Projector <ul style="list-style-type: none"> • 4000 ANSI Lumen DLP Laser based projector /LCD (walls or ceilings mount) • Throw Ratio as required at site • Lamp life: 20000 hrs. or more • Resolution : 1920 X 1080 • Lamp type: Laser • Lens Shift Horizontal: ±20 degrees/Vertical: ±20 degrees or as required by site • Terminals: HDMI, DVI-D, RS 232C Complaint port, LAN RJ-45 network link RGB In with BNC, USB DVI Digital Input Audio In (Mini Jack) VGA Out (Dsub-15pin) • Keystone : yes • Aspect Ratio: 16:9/10 • Warranty: 3 yrs. on site with labor/ parts and maintenance. 2. Computer system: as required to deploy and smooth functioning of the application and integration. 4 or more Headphones (noise cut) are mounted with tables with proper holding kit. 3. Sound system and UPS with cabinet as | One set will comprise of two units of Virtual Presenter of different themes. |

| | | | |
|-----|------------------------------------|---|---|
| | | <p>required at site. Cable dressing and placing of CPU, projector mounting kit and others will be done by SI</p> <p>4. Bilingual Application</p> <p>Scope of Work:</p> <p>A life-size display with a cut-out contour projection screen made of 1” thick acrylic on self-standing structure, on which a specially pre-recorded and formatted film of an animated cartoon human figure will be projected. The acrylic projection screen will exactly match with the animated human silhouette to provide an illusion of a real-life person. The animated human projected figure will activate whenever visitors approach towards the presenter. The visitor can ask some pre-set questions that are displayed in a kiosk, related to the topic chosen and the animated figure shall give the answer which can be done by projecting the right video to display. The visitor may ask question either in Hindi or English. The voice recognition module will recognize the Hindi and English languages. The presenter will be trained with AI Question/answer module so that the visitor can interact with the AI presenter. There may be at least 20 videos embedded that can be triggered on the request or as a solution to the visitor question. The methodology and system architecture for the presenter should be described by the SI. The data flow to address the visitor inquiries can also be neatly designed by SI.</p> <p>NM Delhi will provide the theme. The SI will develop the storyline, animation, scripting, and application. The SI should present their concept in technical presentation.</p> | |
| 10. | Projection based digital flip book | <p>Equipment :</p> <p>1. Projector</p> <ul style="list-style-type: none"> • 4000 ANSI Lumen DLP Laser based projector /LCD (walls or ceilings mount) • Throw Ratio as required at site • Lamp life: 20000 hrs. or more • Resolution : 1920 X 1080 • Lamp type: Laser • Lens Shift Horizontal: ±20 degrees/Vertical: ±20 degrees or as required by site • Terminals: HDMI, DVI-D, RS 232C Complaint port, LAN RJ-45 network link RGB In with BNC, USB DVI Digital Input | One set will comprise of four individual installation of different theme. |

| | | | |
|-----|--|--|--|
| | | <p>Audio In (Mini Jack) VGA Out (Dsub-15pin)</p> <ul style="list-style-type: none"> • Keystone : yes • Aspect Ratio: 16:9/10 • Warranty: 3 yrs. on site with labor/ parts and maintenance. <p>2. Computer system: as required to deploy and smooth functioning of the application and integration. 4 or more Headphones (noise cut) are mounted with tables with proper holding kit.</p> <p>3. Sound system and UPS with cabinet as required at site. Cable dressing and placing of CPU, projector mounting kit and others will be done by SI</p> <p>4. Physical flip book for projection of size 3’X 3’ dummy of 20 pages. The book should be designed with line art.</p> <p>5. Bilingual Application</p> <p>Scope of Work: A setup where a projection will befall on the flipbook. Whenever the visitor changes the page the system senses the page and projected the other content. The content will captivate the visitor by simultaneously illuminating and projecting on the flip book. The content should be experiential content (supported with design, VFX, art works) for digital art or famous places or artifacts or historical events. The flip pages should be at least 20 pages with projected content.</p> <p>NM Delhi will provide the theme. The SI will develop the storyline, animation, scripting, and application. The SI should present their concept in technical presentation.</p> | |
| 11. | Eyeball tracking based digital interaction | <p>Equipment :</p> <p>1. Projector</p> <ul style="list-style-type: none"> • 4000 ANSI Lumen DLP Laser based projector /LCD (walls or ceilings mount) • Throw Ratio as required at site • Lamp life: 20000 hrs. or more • Resolution : 1920 X 1080 • Lamp type: Laser • Lens Shift Horizontal: ±20 degrees/Vertical: ±20 degrees or as required by site • Terminals: HDMI, DVI-D, RS 232C Complaint port, LAN RJ-45 network link RGB In with BNC, USB DVI Digital Input Audio In (Mini Jack) VGA Out (Dsub-15 | One set will comprise of two Eyeball tracking based digital interaction. |

| | | | |
|--|--|---|--|
| | | <p>pin)</p> <ul style="list-style-type: none"> • Keystone : yes • Aspect Ratio: 16:9/10 • Warranty: 3 yrs. on site with labor/ parts and maintenance. <p>2. Computer system: as required to deploy and smooth functioning of the application and integration. 4 or more Headphones (noise cut) are mounted with tables with proper holding kit.</p> <p>3. A 32'' display with a graphical scenario for tracking graphics</p> <p>4. Sound system or headphones (As desired by the site) and UPS with cabinet as required at site. Cable dressing and placing of CPU, projector mounting kit and others will be done by SI</p> <p>5. Physical setup of the exhibit with eye trackers.</p> <p>6. Bilingual Application</p> <p>Scope of Work: The apps will track the visitor's eyeball position on the 32'' display. The visitor will trigger a hotspot with their movement of the eyeball and the further demonstration of the object will be projected on the projection screen. The visitor can close the demonstrating frame on seeing a sufficient amount of time (maybe 5 sec) on a close button. There will be four no. of graphical designs (aesthetically designed) with 10 hotspots each. Visitor can change the digital graphics with the switch or button on the 32'' display.</p> <p>NM Delhi will provide the theme. The SI will develop the storyline, animation, scripting, and application. The SI should present their concept in technical presentation.</p> | |
|--|--|---|--|

Setup, Deployment and Commissioning:

The SI will be responsible to set up the entire system with proper accessories casing and display cases. The power cabling, data cabling with the system from the source to destination will neatly be done by SI. SI must ensure all the systems with proper UPS for power backup. All the equipment should have BIS certification and environmental compliance. The scope of work is not exhaustive and can be modified by NM Delhi / NCSM with mutual consent to upgrade the immersive experience of the gallery. The hardware and the software chosen should be of latest model and the warranty from OEM should be taken for 3 years and all licenses proposed should be licensed for lifetime. The System architecture, hardware list, System application format, know/how booklet and manual of each exhibit should be provided by the SI. The SI will provide all the software with source code to NM, Delhi and NCSM.

Design, Supply, Installation, Testing and Commissioning of all Hardware, Software, Content Development and Display Cases for Central Content Device Management Software System and Server based Cross Platform Web Applications including appropriate Media Server/Computer Server/CPU along with all cables and display cases for managing all the devices and contents that have been listed in this tender

| Sl. No | Item Description | Specification | Quantity |
|--------|--------------------------|---|----------|
| 1. | Software Specification | Design and Development of Content Management system with a Server based Cross Platform Web Applications Manage all stations centrally from one location Custom Content Layout Third Party Integration (Facebook ,Twitter, Google Sheets etc) Unlimited Users Station Monitoring Remote Showdown / Update / Restart of Client devices Custom Control using Tablet / Mobile Audio Streaming Virtual Keyboard & Mouse Access (Remotely Access keyboard / Mouse of client device) Video Format Support - mp4/ avi/ mov /h264 etc Audio Support -mp3 Embed Webpage / HTML Content Embed External Application Live Streaming Integration IOT Integration Content Scheduling (Based on time & Date) Kiosk Mode (with password protection) Dashboard Customization System Health Monitoring Emergency Alert Email Notification External API Integration Smart Caching Communicate with Hardware devices using RS232/IP Control Input Sources / Hardware Properties | 1 |
| 2 | License Type | Perpetual | |
| 3. | Operating System Support | Operating System Support - Windows 10/ 8.1 , Linux, Mac OS | |
| 4 | Computer System | Operating System Windows 10 professional or similar as required for the CCC Chassis 19’’ industrial rack mount, lockable front door to protect drives CPU Xeon i7 six Core / AMD Thread ripper based server 3.0 GHz or higher GPU NVIDIA with 4 outputs supporting GDDR5 8GB or equivalent RAM 16 Gb DDR4 or more RAID 0, 1, 5, 10 support Hard Disk R.A.I.D-1 redundant setup with 2x | |

Annexure J

Format for the Cost Break Up list (Bidder may add row according to their requirement)

| 1.01 Design, Supply, Installation, Testing and Commissioning of all Hardware, Software, Content Development for 55 inch or more Transparent OLED Digital Signage Display including appropriate Media Server/Computer Server/CPU along with all cables and display enclosure for showcasing masterpiece Objects of NM the details of which will be provided by National Museum. (Annexure I-(a)) | | | | | | |
|--|-------|----------|---------------|----------|------------|----------------------------|
| Sl. No | Items | Quantity | Rate per Item | GST Rate | GST amount | Total Amount Including tax |
| Equipment | | | | | | |
| | | | | | | |
| Software | | | | | | |
| | | | | | | |
| Content Development | | | | | | |
| | | | | | | |
| Cabinet Cases/ Cables/ power adaptors / other minor items | | | | | | |
| | | | | | | |
| Installation , Commissioning | | | | | | |
| | | | | | | |
| 1.02 Design, Supply, Installation, Testing and Commissioning of all Hardware, Software, Content Development for 5x2 grid thin bezel multi-touch LED Digital Display Wall using 46-48 inch LED digital signage including appropriate Media Server/Computer Server/CPU along with all cables and display enclosure for interactive display of NM Objects the details of which will be provided by National Museum. (Annexure I-(b)) | | | | | | |
| Sl. No | Items | Quantity | Rate per Item | GST Rate | GST amount | Total Amount Including tax |
| Equipment | | | | | | |
| | | | | | | |
| Software | | | | | | |
| | | | | | | |
| Content Development | | | | | | |
| | | | | | | |
| Cabinet Cases/ Cables/ power adaptors / other minor items | | | | | | |
| | | | | | | |
| Installation , Commissioning | | | | | | |
| | | | | | | |

| |
|--|
| 1.03 Design, Supply, Installation, Testing and Commissioning of all Hardware, Software, Content Development for Large Indoor P 2.5mm LED wall with Holographic illusion (Pepper-Ghost Pyramidal Holographic display) including appropriate Media Server/Computer Server/CPU along with all cables for display of video content on National Museum and its Objects for which information will be provided by National Museum. (Annexure I-(c)) |
|--|

| Sl. No | Items | Quantity | Rate per Item | GST Rate | GST amount | Total Amount Including tax |
|--|-------|----------|---------------|----------|------------|----------------------------|
| Equipment | | | | | | |
| | | | | | | |
| Software | | | | | | |
| | | | | | | |
| Content Development | | | | | | |
| | | | | | | |
| Cabinet Cases/ Cables/ power adaptors / other minor items | | | | | | |
| | | | | | | |
| Installation , Commissioning | | | | | | |
| | | | | | | |
| 1.04 Design, Supply, Installation, Testing and Commissioning of all Hardware, Software, Content Development for Orientation Film by way of 3-Wall Projection Mapping Show using DLP Laser Phosphor Projectors with necessary lenses including appropriate Media Server/Computer Server/CPU along with all cables for giving brief information about all the galleries of National Museum, the brief write-up on which will be provided by National Museum. (Annexure I-(d)) | | | | | | |
| Sl. No | Items | Quantity | Rate per Item | GST Rate | GST amount | Total Amount Including tax |
| Equipment | | | | | | |
| | | | | | | |
| Software | | | | | | |
| | | | | | | |
| Content Development | | | | | | |
| | | | | | | |
| Cabinet Cases/ Cables/ power adaptors / other minor items | | | | | | |
| | | | | | | |
| Installation , Commissioning | | | | | | |
| | | | | | | |

| 1.05 Design, Supply, Installation, Testing and Commissioning of all Hardware, Software, Content Development and Display system for Technology Engagement for each of the 10 galleries by using any two of the listed technologies as per annexure-I(e) including appropriate Media Server/Computer Server/CPU along with all cables for giving detailed information about the masterpiece/selected Objects of the gallery, which will be provided by National Museum. (Annexure I-(e)) | | | | | | |
|---|-------|----------|----------|----------|------------|--------------|
| Sl. No | Items | Quantity | Rate per | GST Rate | GST amount | Total Amount |

| | | | | | | |
|---|--------------|-----------------|----------------------|-----------------|-------------------|-----------------------------------|
| | | | Item | | | Including tax |
| Equipment | | | | | | |
| | | | | | | |
| Software | | | | | | |
| | | | | | | |
| Content Development | | | | | | |
| | | | | | | |
| Cabinet Cases/ Cables/ power adaptors / other minor items | | | | | | |
| | | | | | | |
| Installation , Commissioning | | | | | | |
| | | | | | | |
| 1.06 Design, Supply, Installation, Testing and Commissioning of all Hardware, Software, Content Development for Central Content Device Management Software System including appropriate Media Server/Computer Server/CPU along with all cables and networking component for managing all the devices and contents that have been listed in this tender. (Annexure I-(f)) | | | | | | |
| Sl. No | Items | Quantity | Rate per Item | GST Rate | GST amount | Total Amount Including tax |
| Equipment | | | | | | |
| | | | | | | |
| Software | | | | | | |
| | | | | | | |
| Content Development | | | | | | |
| | | | | | | |
| Cabinet Cases/ Cables/ power adaptors / other minor items | | | | | | |
| | | | | | | |
| Installation , Commissioning | | | | | | |
| | | | | | | |

| | | | |
|---|-----------------|-------------------|----------------------|
| 1.07 Comprehensive Annual Maintenance Contract Charges for the 1st year after the defect liability period of 1 year | | | |
| Charges | GST Rate | GST amount | Total Charges |
| | | | |
| 1.08 Comprehensive Annual Maintenance Contract charges for the 2nd year after the defect liability period of 1 year | | | |
| Charges | GST Rate | GST amount | Total Charges |
| | | | |

Floor Plan and other drawings

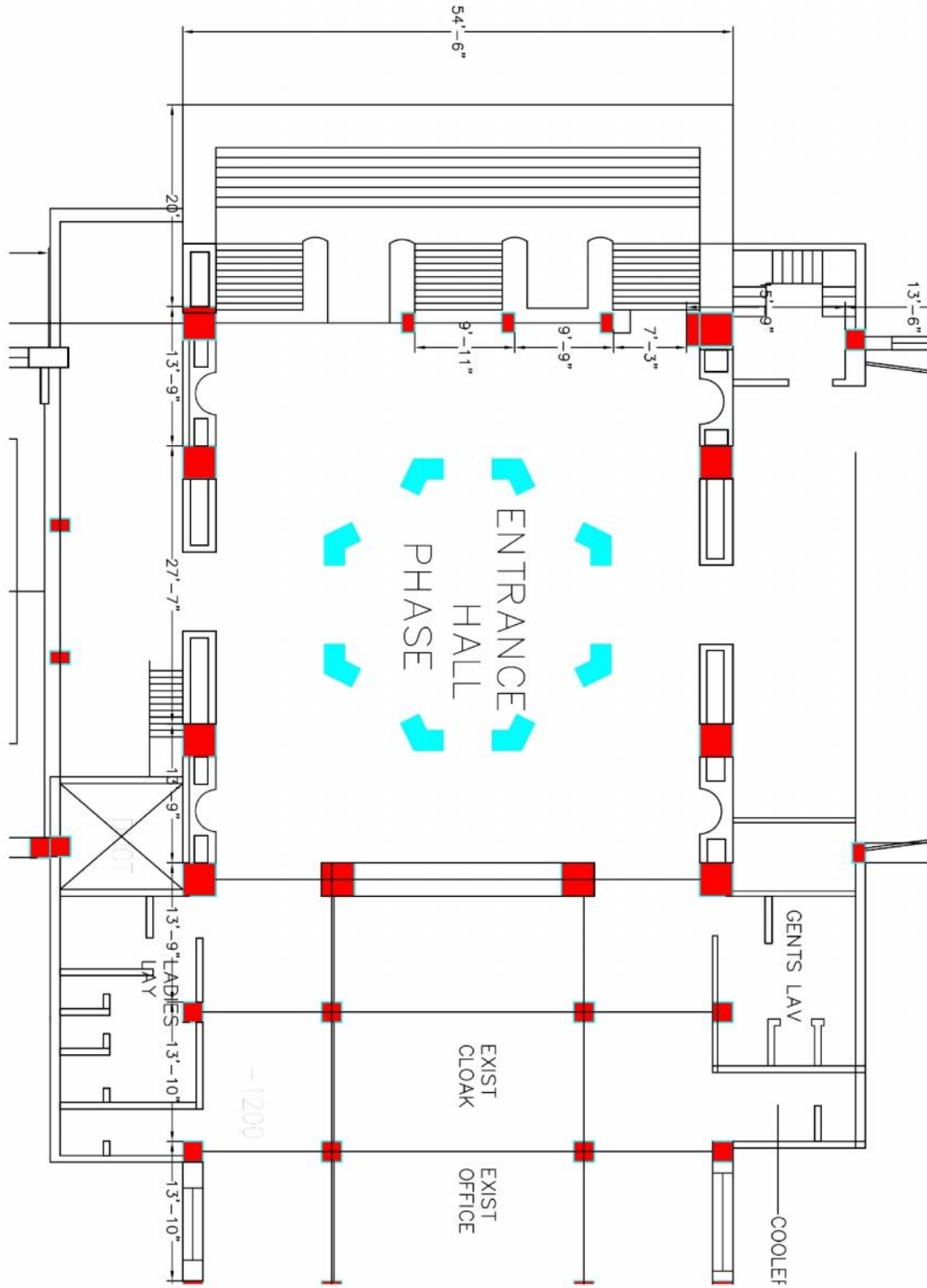

Name of the work: Supply, Installation, Integration, Testing, Commissioning and three years onsite maintenance of "DIGITAL & IMMERSIVE EXPERIENCE IN THERECEPTION HALL AND OTHER AREAS AT NATIONAL MUSEUM, NEW DELHI".

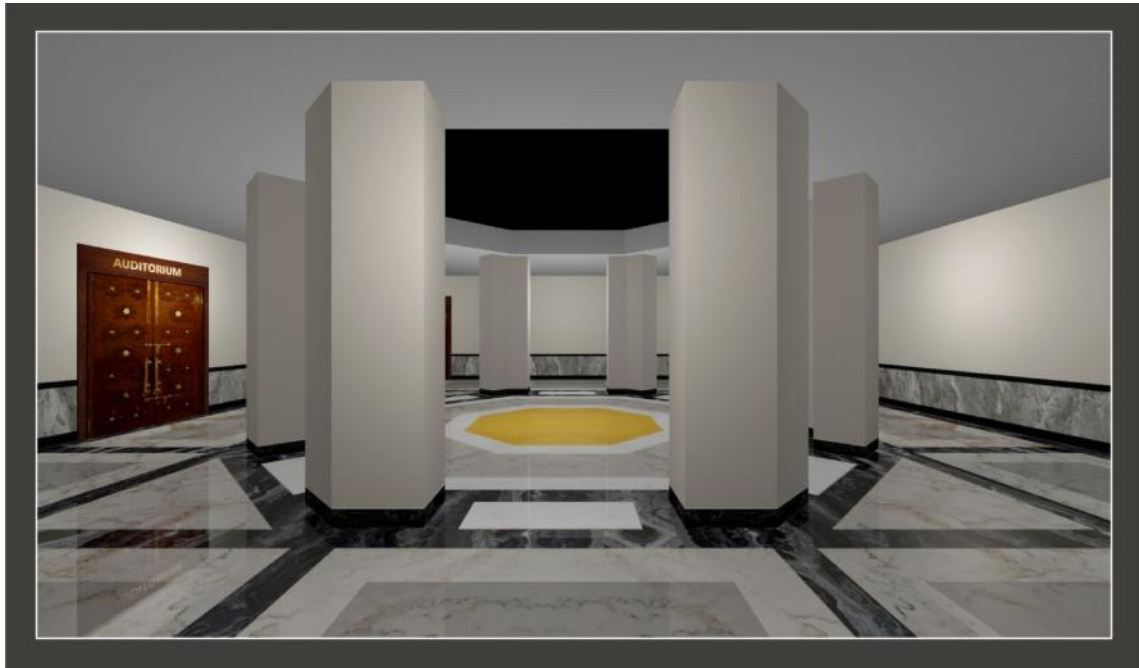

Name of the work: Supply, Installation, Integration, Testing, Commissioning and three years onsite maintenance of **"DIGITAL & IMMERSIVE EXPERIENCE IN THERECEPTION HALL AND OTHER AREAS AT NATIONAL MUSEUM, NEW DELHI"**.

CHECK LIST

| Sl. No. | Nomenclature | Yes/No |
|---------|---|--------|
| 1 | Whether the Tender documents have been completely read, understood and accepted | |
| 2 | Whether soft copy of EMD of Rs.14.00 lakh has been uploaded | |
| 3 | Whether hard copy of EMD has been submitted to NCSM | |
| 4 | Whether fund transfer details such as UTR Number, date etc. have been uploaded | |
| 5 | Whether the Bid is valid for 90 days from the date of opening of financial bids | |
| 6 | Whether Technical (Techno-Commercial) Bid” (as per Annexure-B format) has been duly filled in and digitally signed with official stamp. | |
| 7 | Whether all relevant documents related to “Technical (Techno-commercial) Bid” as per Annexure-B have been uploaded | |
| 8 | Whether the Technical Brochures of each equipment with technical explanation for every feature of the product offered have been uploaded. | |
| 9 | Whether the scanned copy of Scope of Work, Bill of Quantities, General Terms & Conditions etc. (Annexure-A) duly signed by the Authorized Signatory with official stamp as a token of acceptance of the same have been uploaded. | |
| 10 | Whether the Financial Bid (BOQ)” (as per Detailed Scope of Work and Bill of Quantities) i.e. Schedule of Price Bid in the item wise tabular format have been duly filled in and digitally signed | |
| 11 | Whether the BOQ has been filled up for all the items mentioned or not. | |
| 12 | Whether “Cost Break-up” for each quoted components (as per Detailed Scope of Work, Bill of Quantities and Annexure-I) duly filled in tabular format as per Annexure-J and digitally signed with official stamp. | |
| 13 | Whether documentary proof for One similar work of value not less than Rs. 5.50 Crore of the estimated cost of work. Or Two similar works each of value not less than Rs. 4.25 Crore of estimated cost of work. Or Three similar works each of value not less than Rs. 2.75Crore of estimated cost of work has been uploaded(Please specify) | |
| 14 | Whether Agency Experience (Private/PPP/Joint Venture Projects) (Annexure-D) has been filled up and uploaded | |
| 15 | Whether format for availability of Technical Team (Annexure-E) has been filled up and uploaded | |
| 16 | Whether format for annual turnover (Annexure-F) has been filled up and uploaded | |
| 17 | Whether Declaration as per Annexure-G has been signed and uploaded | |
| 18 | Whether the Format for Articles of Agreement (Annexure-H) has been read | |
| 19. | Whether the detailed technical specification has been read and understood | |
| 20. | Whether the site condition has been assessed. | |